



### I Application

The INNOVA G-type valve is a pneumatic flow control single seat valve for hygienic applications. Its main function involves regulating flow, controlling pressure and level.

The plug's design enables equal percentage flow control to obtain the required Kv factor. This type of control is recommended for systems with significant flow or differential pressure variations.

Positioning is controllable either manually or using a process parameter via the positioning sensor.

### I Design and features

Normally closed (NC) valve without seal in the plug.

Equal percentage control plug.

Dual function positioner: position controller (PD) or process controller (PID).

Easy assembly/disassembly of internal parts by loosening a clamp fastener.

Open lantern allows visual inspection of shaft sealing.

360° adjustable body.

### I Technical specifications

#### Materials:

Parts in contact with the product *AISI 316L (1.4404)*

Other stainless steel parts *AISI 304 (1.4301)*

Gasket *EPDM*

#### Surface finish:

Internal *Bright polish  $Ra \leq 0,8 \mu m$*

External *Matt*

#### Available sizes:

DIN 11850 *DN 25 – DN 100*

ASME BPE *OD 1" – OD 4"*

#### Connections:

*Weld*

#### Operating limits:

Temperature range (EPDM) *-10 °C to +121 °C 14 °F to 250 °F*

SIP temperature, max. 30 min. *140°C 284°F*

Maximum working pressure *10 bar 145 PSI*

Minimum working pressure *Vacuum Vacuum*

Compressed air pressure *6-8 bar 87-116 PSI*

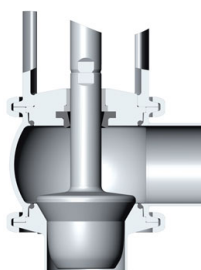

Equal percentage  
regulating plug



### I Options

Double-acting pneumatic actuator.

Gaskets: *FPM, HNBR.*

Seat seal.

Other connection types.

Surface finish:  *$Ra \leq 0,5 \mu m$ .*

Jacketed body.

Steam barrier.



I Housing combinations

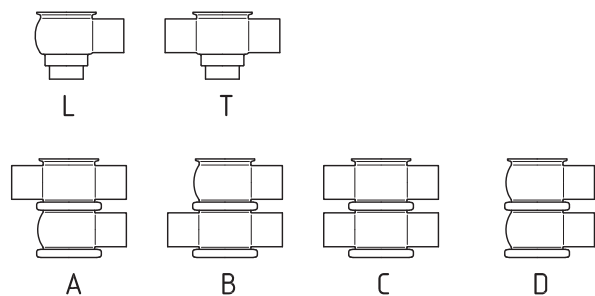

I Dimensions

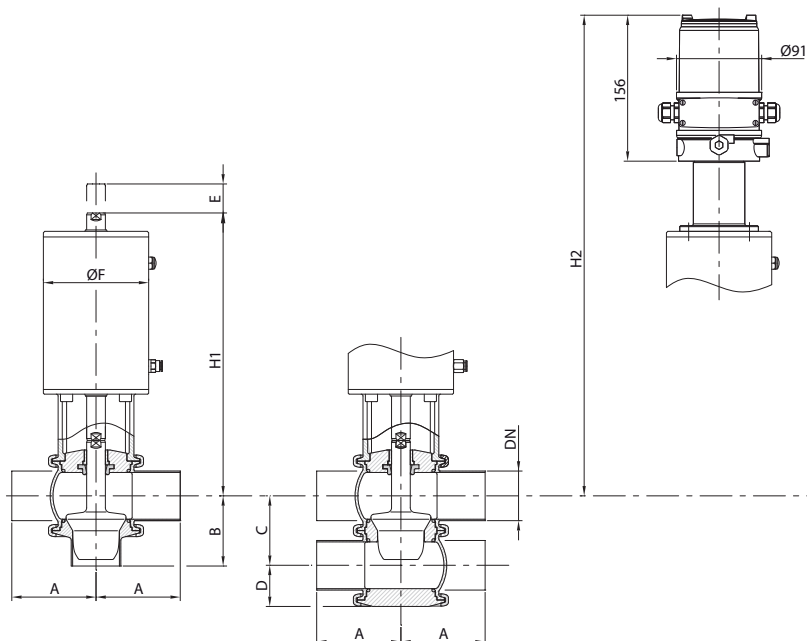

	DN	Pipe Ø	A	B	C	D	E	Ø F	H <sub>1</sub>	H <sub>2</sub>	kg
DIN	25	29 x 1,5	50	50	50	32	15	87	239	436	4,5
	40	41 x 1,5	85	60	62	38	23	87	242	446	5,5
	50	53 x 1,5	90	70	74	44	31	112	303	517	10
	65	70 x 2,0	110	90	92	53	36	143	350	569	17
	80	85 x 2,0	125	90	107	60	35	143	358	576	19
	100	104 x 2,0	150	125	127	70	30	216	387	603	34
OD	1"	25,4 x 1,65	50	50	46	30	11	87	241	438	4,5
	1½"	38,1 x 1,65	85	60	59	36	20	87	243	448	5,5
	2"	50,8 x 1,65	90	70	72	43	29	112	304	518	10
	2½"	63,5 x 1,65	110	90	86	50	30	143	353	572	17
	3"	76,2 x 1,65	125	90	99	56	27	143	362	580	18
	4"	101,6 x 2,11	150	125	124	69	28	216	388	601	34

**I Sizing**

Use the Kv factor to size the control valves, which relates the drop in pressure with the flow.

The Kv factor indicates the flow in m³/h for a 1 bar drop in pressure.

The Kv values are calculated for water at temperatures of 5°C to 30°C.

The following formula can calculate the required Kv for products with a similar density and viscosity to water:

$$Kv = \frac{Q}{\sqrt{\Delta p}}$$

where:

Q = flow in m³/h

Δp = drop in pressure in the valve

The selected Kv<sub>S</sub> factor should be higher than the required Kv factor to ensure enough margin for the control function. This involves applying a safety coefficient

$$Kv_S > Kv_r = \frac{Kv}{0,7}$$

Example:

Q = 18 m³/h

Δp = 0,5 bar

$$Kv = \frac{18}{\sqrt{0,5}} = 25,5 \text{ m}^3/\text{h}$$

$$Kv_r = \frac{25,5}{0,7} = 36,4 \text{ m}^3/\text{h}$$

This value indicates that the DN-50 (Kv<sub>S</sub> = 40) would be the most suitable valve.

Ask the technical department regarding cases involving viscous products.

