



**I Application**

The L type valve is a pneumatic divert single seat valve with diverging flow designed for hygienic applications. The plug is specifically designed to manage diverging flows, given that it closes against the direction of flow (inlet via the central body and outlet via the upper or lower bodies).

**I Design and features**

As standard, the lower body is the closure section, whilst the upper body is for diversion. Simply invert the actuator for upper body closure with diversion to the lower body. Easy to maintain with access to the internal parts by loosening the body clamp. Open lantern allows visual inspection of the shaft sealing. 360° adjustable bodies.

**I Technical specifications**

*Operating limits:*

Maximum working temperature	+120 °C	248 °F
Temperature SIP, max. 30 min	+140 °C	284 °F
Maximum working pressure	10 bar	145 PSI
Minimum working pressure	Vacuum	Vacuum
Compressed air pressure	6-8 bar	87-116 PSI

*Materials:*

Parts in contact with the product	AISI 316L
Other stainless steel parts	AISI 304
Gasket in contact with the product	EPDM

*Surface finish:*

Internal	Polished Ra ≤ 0,8 µm
External	Matt

*Available sizes:*

DIN EN 10357 series A (previously DIN 11850 series 2)	DN 25 - DN 100
--	----------------

ASTM A269/270

(corresponds to OD pipe)	DN 1"- DN 4"
--------------------------	--------------

Connections

Weld

**I Options**

- Double-acting pneumatic actuator.
- Gaskets: FPM, HNBR.
- Other connection types.
- C-TOP+ control unit.
- External position sensors.
- Steam barrier.
- Bodies with heating jacket.
- Internal surface finish: Ra ≤ 0,5 µm.



I Housing combinations

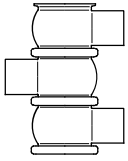

J

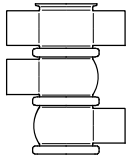

P

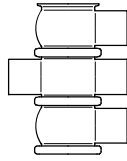

R

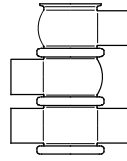

S

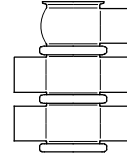

V

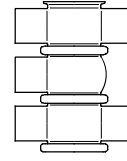

W

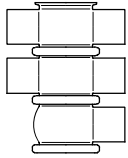

X

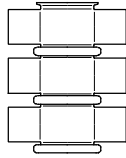

Z

I Dimensions

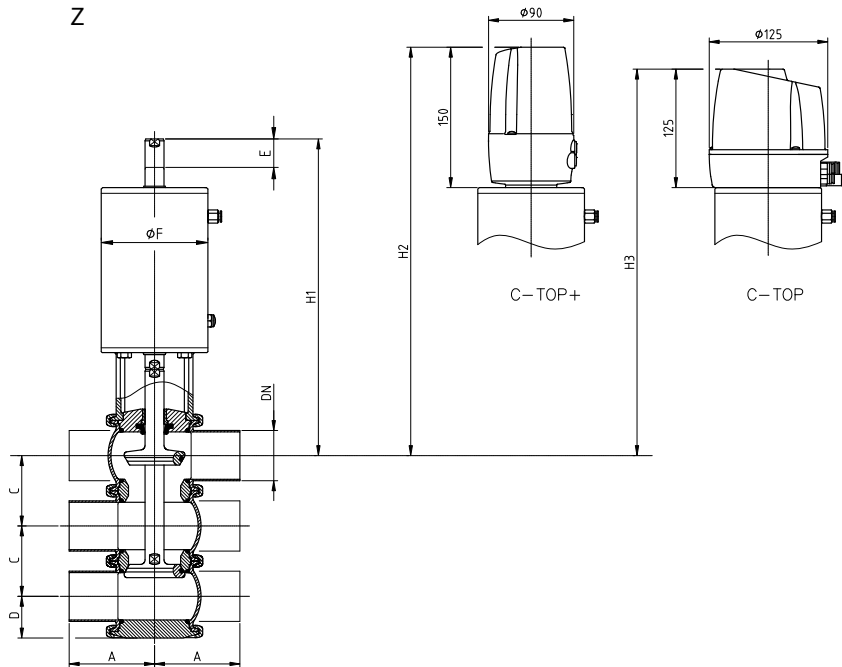

	DN	Pipe Ø	A	C	D	Ø F	E	H <sub>1</sub>	H <sub>2</sub>	H <sub>3</sub>	kg
DIN	25	29 x 1,5	50	50	32	87	13	251	367	342	6
	40	41 x 1,5	85	62	38	87	15	256	377	352	8
	50	53 x 1,5	90	74	44	112	23	325	433	408	12
	65	70 x 2,0	110	92	53	143	24	372	485	460	20
	80	85 x 2,0	125	107	60	143	19	374	492	467	24
	100	104 x 2,0	150	127	70	216	26	408	516	491	42
OD	1"	25,4 x 1,65	50	46	30	87	8	249	369	344	6
	1½"	38,1 x 1,65	85	59	36	87	18	261	379	354	8
	2"	50,8 x 1,65	90	72	43	112	25	329	434	409	12
	2½"	63,5 x 1,65	110	86	50	143	30	380	488	463	20
	3"	76,2 x 1,65	125	99	56	143	27	386	496	471	23
	4"	101,6 x 2,11	150	124	69	216	28	412	517	492	42

Maximum pressure in bar / PSI without leakage at the valve seat.

Actuator/valve body combination and direction of pressure	Air pressure [bar] / [PSI]	Plug position	OD 1" DN 25	OD 1½" DN 40	OD 2" DN 50	OD 2½" DN 65	OD 3" DN 80	OD 4" DN 100
			[bar] / [PSI]					
	-	NC	10 / 145	6 / 87	6,1 / 89	6,3 / 91	5,3 / 77	5,6 / 81
	6 / 87	NC	10 / 145	8,2 / 119	5,6 / 81	5,9 / 85	5,2 / 76	10 / 145
	-	NO	10 / 145	5,7 / 82	5,1 / 74	5,1 / 74	4,4 / 64	4,7 / 68
	6 / 87	NO	10 / 145	7,4 / 107	4,5 / 65	5,6 / 81	4,7 / 68	10 / 145
	6 / 87	A/A	10 / 145	10 / 145	10 / 145	10 / 145	10 / 145	10 / 145
	6 / 87	A/A	10 / 145	10 / 145	10 / 145	10 / 145	10 / 145	10 / 145

Maximum pressure in bar / PSI against which the valve can open.

Actuator/valve body combination and direction of pressure	Air pressure [bar] / [PSI]	Plug position	OD 1" DN 25	OD 1½" DN 40	OD 2" DN 50	OD 2½" DN 65	OD 3" DN 80	OD 4" DN 100
			[bar] / [PSI]					
	-	NC	10 / 145	9,1 / 132	9,7 / 141	8,4 / 121	7 / 102	10 / 145
	6 / 87	NC	10 / 145	10 / 145	10 / 145	8,3 / 121	7,1 / 102	5,4 / 78
	-	NO	10 / 145	10 / 145	10 / 145	9 / 131	7,6 / 110	7,7 / 11
	6 / 87	NO	10 / 145	10 / 145	10 / 145	8,6 / 125	7,7 / 111	10 / 145

A = Air  
 P = Product pressure  
 NC = Normally closed  
 NO = Normally open  
 A/A = Double acting

Note: Values for standard actuators.  
 For other pressures, bigger actuators can be assembled.