

I Application

The INNOVA D-type valve is a pneumatic shut-off single seat valve with two seals that, by means of a leakage chamber under atmospheric pressure formed between the two seals, enables a safe separation of two different products, one of which is usually CIP (cleaning medium).

Compressed air is simultaneously applied to the actuator and to the leakage valves to prevent leakage through the leakage valve when the valve opens. Valve open - leakage valves closed / valve closed - leakage valves open.

The leakage chamber can be cleaned through one of the two available leakage valves.

I Design and features

- Specific profile seat seals, conical upper seal, radial lower seal.
- Main valve with single acting actuator (NC) and normally open leakage valves (NO).
- Easy assembly/disassembly of internal parts by loosening a clamp fastener.
- Open lantern allows visual inspection of shaft sealing.
- 360° adjustable body.

I Technical specifications

Materials:

Parts in contact with the product	Stainless steel AISI 316L (1.4404)
Other stainless steel parts	Stainless steel AISI 304 (1.4301)
Gasket	EPDM

Surface finish:

Internal	Bright polish Ra ≤ 0,8 µm
External	Matt

Available sizes:

DIN 11850	DN 25 – DN 100
ASME BPE	OD 1" – OD 4"

Connections:

Weld

Operating limits:

Temperature range (EPDM)	-10 °C to +121 °C	14 °F to 250 °F
SIP temperature, max. 30 min.	140°C	284°F
Maximum working pressure	10 bar	145 PSI
Minimum working pressure	Vacuum	Vacuum
Compressed air pressure	6-8 bar	87-116 PSI

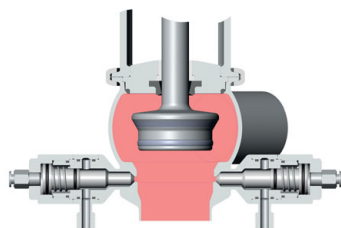

Valve open.
Leakage valves closed.

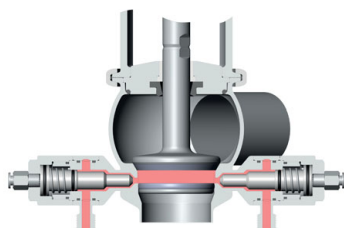

Valve closed.
Leakage valves open for draining or cleaning of the leakage chamber.

I Options

- Double-acting pneumatic actuator.
- Gaskets: FPM, HNBR.
- Other connection types.
- C-TOP+ control unit.
- External position sensors.
- Surface finish: Ra ≤ 0,5 µm.



I Housing combinations

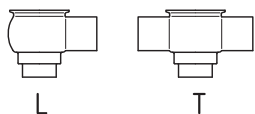

I Dimensions

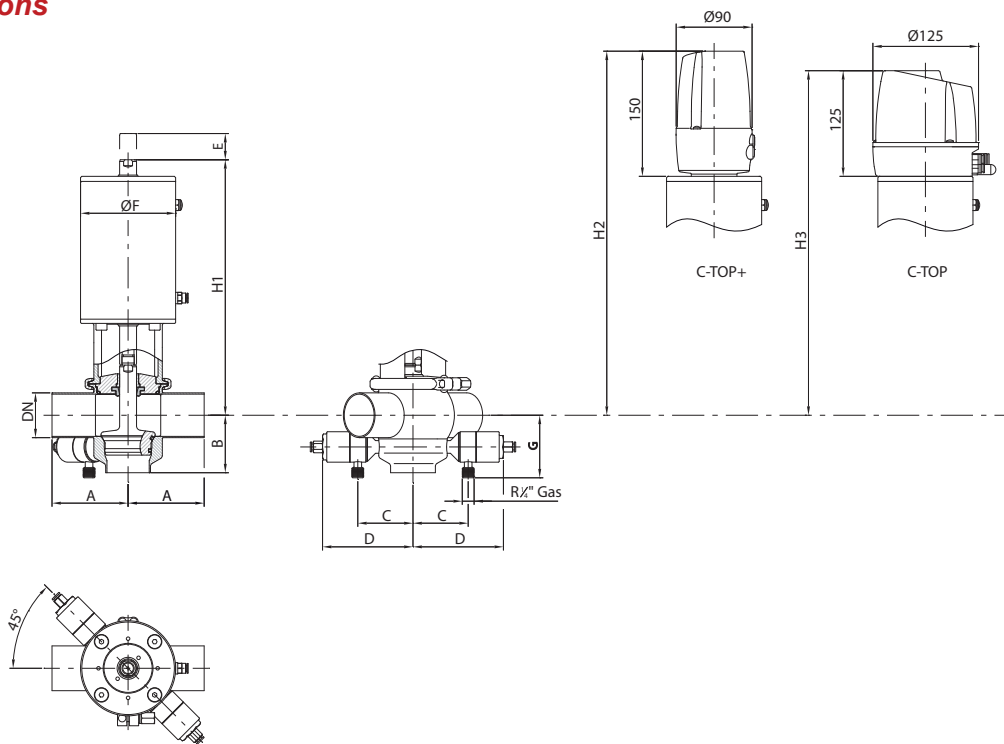

	DN	Pipe Ø	A	B	C	D	E	Ø F	G	H ₁	H ₂	H ₃	kg
DIN	25	29 x 1,5	50	50	50	92	17	87	62	238	367	342	5,1
	40	41 x 1,5	85	60	59	101	24	87	68	241	377	352	6,1
	50	53 x 1,5	90	68	65	107	31	112	74	303	433	408	10
	65	70 x 2,0	110	81	77	119	38	143	82	348	485	460	17
	80	85 x 2,0	125	90	83	125	38	143	90	356	492	467	19
	100	104 x 2,0	150	125	95	137	34	216	100	383	516	491	34
OD	1"	25,4 x 1,65	50	50	50	92	13	87	60	240	369	344	5,1
	1½"	38,1 x 1,65	85	60	59	101	21	87	67	243	379	354	6,1
	2"	50,8 x 1,65	90	68	65	107	29	112	72	304	434	409	10
	2½"	63,5 x 1,65	110	81	77	119	32	143	79	351	488	463	17
	3"	76,2 x 1,65	125	90	83	125	30	143	86	360	496	471	18
	4"	101,6 x 2,11	150	125	95	137	31	216	99	384	517	492	34

Maximum pressure in bar / PSI without leakage at the valve seat.

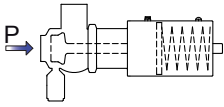
Actuator/valve body combination and direction of pressure	Air pressure	Plug position	OD 1"	OD 1½"	OD 2"	OD 2½"	OD 3"	OD 4"
	[bar] / [PSI]		DN 25	DN 40	DN 50	DN 65	DN 80	DN 100
	6 / 87	NC	10 / 145	5,7 / 82	5,1 / 74	5,1 / 74	4,4 / 64	4,7 / 68

Maximum pressure in bar / PSI against which the valve can open.

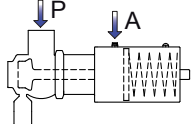
Actuator/valve body combination and direction of pressure	Air pressure	Plug position	OD 1"	OD 1½"	OD 2"	OD 2½"	OD 3"	OD 4"
	[bar] / [PSI]		DN 25	DN 40	DN 50	DN 65	DN 80	DN 100
	6 / 87	NC	10 / 145	10 / 145	10 / 145	8,6 / 125	7,7 / 111	10 / 145

A = Air

P = Product pressure

NC = Normally closed

Note: Values for standard actuators.

For other pressures, bigger actuators can be assembled.