

SANITARY PRESSURE REDUCING VALVE P130L

DESCRIPTION

The ADCA P130L low flow series direct acting, spring-loaded diaphragm sensing pressure reducing valves are designed for use with clean air, nitrogen, carbon dioxide, oxygen, argon and other gases or liquids compatible with the construction materials and valve design. This valve is specifically designed for the high purity gas systems found in the pharmaceutical, cosmetic, fine chemical and food & beverage processes.

The valve is available in a dome loaded version.

MAIN FEATURES

Compact design.
Completely machined from 316L stainless steel bar stock, no castings or forgings are used.
FDA / USP Class VI compliant seals.
Non-rising adjustment knob.

STANDARD SURFACE FINISH

Internal wetted parts: $\leq 0,51$ micron Ra – SF1.
External: $\leq 0,76$ micron Ra – SF3.
Other surface conditions see IS PV20.00 E – Technical information.
Ultrasonic cleaning.

OPTIONS:

- Self relieving.
- Leakage line connection 1/8" (captured vent).
- Panel mounting version (thread M45).
- Gauge connection on body.
- Different soft valves for liquids and gases.
- Wall mounting.
- Dome-loaded version.

USE: Clean air, nitrogen, carbon dioxide, oxygen, argon and other gases or liquids compatible with the construction.

AVAILABLE MODELS: P130L – low flow.

SIZES: 1/2" to 3/4"; DN 08 to DN 20.

REGULATING RANGES: 0,2 to 1,5 bar; 0,3 to 3 bar; 2 to 8 bar.

CONNECTIONS: ASME BPE, DIN and ISO clamp ferrules or tube weld (ETO) ends.
Others on request.

PACKAGING: Assembling and packaging in a clean room certified according to ISO 14644-1.
The product is end capped and sealed with recyclable thermo-shrinkable plastic film, to avoid contamination.

INSTALLATION: Any position.
See IMI – Installation and maintenance instructions.

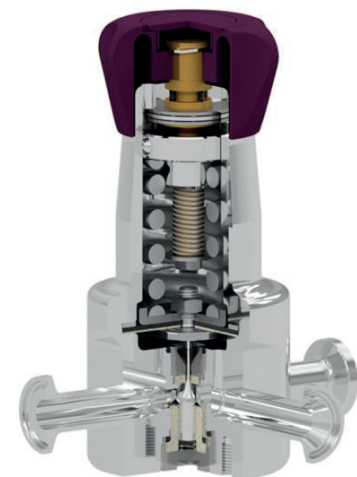

LIMITING CONDITIONS

Valve model	P130L
Body design conditions	PN 16
Maximum upstream pressure	16 bar
Maximum downstream pressure	8 bar
Minimum downstream pressure	0,2 bar
Maximum design temperature *	150 °C

* Others on request.

CE MARKING – GROUP 2 (PED – European Directive)

PN 16	Category
1/2" to 3/4" – DN 08 to 20	SEP

FLOW RATE COEFFICIENTS (m³/h)

SIZE	ASME BPE			DIN			ISO		
	1/2" to 3/4"			DN 10 to DN 20			DN 08 to DN 15		
Kvs	0,06	0,19	0,25	0,06	0,19	0,25	0,06	0,19	0,25

DIMENSIONS (mm) ASME BPE

SIZE	A	B	C	D	d1	d2	E	F	H	WEIGHT (kg) *
1/2"	115	23	120	64	25	15,75	65	25	9,4	2,13
3/4"	115	23	120	64	25	15,75	65	25	15,75	2,14

* Valves with nylon adjustment knob weigh 0,3 kg less.

DIMENSIONS (mm) DIN

SIZE	A	B	C	D	d1	d2	E	F	H	WEIGHT (kg) *
DN 10	115	23	120	64	25	15,75	65	34	10	2,11
DN 15	115	23	120	64	25	15,75	65	34	16	2,13
DN 20	115	23	120	64	25	15,75	65	34	20	2,15

* Valves with nylon adjustment knob weigh 0,3 kg less.

Remarks: Clamp ferrules according to DIN 32676-A; Tube weld (ETO) according to DIN 11866-A (DIN 11850-2).

DIMENSIONS (mm) ISO

SIZE	A	B	C	D	d1	d2	E	F	H	WEIGHT (kg) *
DN 08	115	23	120	64	25	15,75	65	25	10,3	2,11
DN 10	115	23	120	64	25	15,75	65	25	14	2,12
DN 15	115	23	120	64	25	15,75	65	50,5	18,1	2,13

* Valves with nylon adjustment knob weigh 0,3 kg less.

Remarks: Clamp ferrules according to DIN 32676-B; Tube weld (ETO) according to DIN 11866-B (ISO 1127).

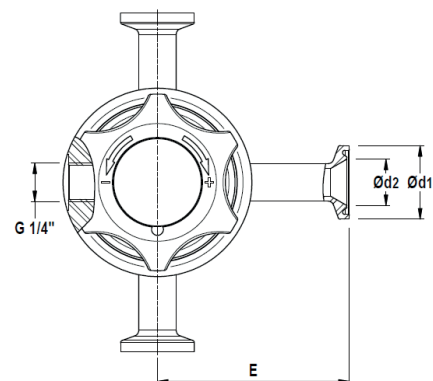
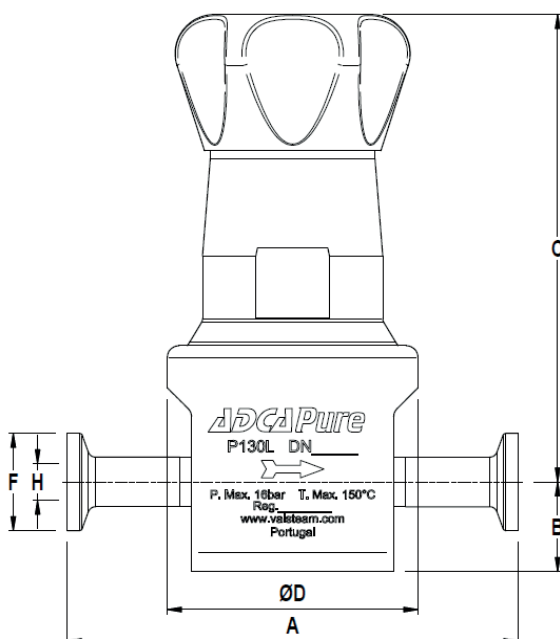

Optional pressure gauge connection.

MATERIALS

POS. N°	DESIGNATION	MATERIAL
1	Valve body	AISI 316L / 1.4404
2	Cover	AISI 316L / 1.4404
3	Bottom cover	AISI 316L / 1.4404
4	* O-ring	Viton; EPDM
5	* Plug	AISI 316L / 1.4404
6	* Valve seat seal	TFM 1600, EPDM, ...
8	* Valve spring	AISI 316 / 1.4401 electropolished
9	* Valve seat	AISI 316L / 1.4404
10	* O-ring	EPDM
11	Guide	TFM 1600
13	* O-ring a)	EPDM
14	Pusher disk	AISI 316L / 1.4404
15	* Lower diaphragm	PTFE (Gylon)
16	* Upper diaphragm	EPDM
17	Washer	AISI 304 / 1.4301
18	Plate	AISI 316 / 1.4401
19	Nut	Stainless steel A2-70
20	* Serrated washer	AISI 304 / 1.4301
21	* Adjustment spring	AISI 302 / 1.4300
22	Spring guide	AISI 316 / 1.4401
23	Adjustment screw	Brass
24	Washer	Stainless steel A2-70
25	Bolt	Stainless steel A2-70
26	Adjustment knob	AISI 316L / 1.4404 or Nylon
27	O-ring	NBR
28	Bearing	Corrosion resistant steel
29	Shaft ring	Stainless steel
30	Cover nut	Plastic
31	Leakage line / Captured vent ring	AISI 316L / 1.4404
32	* O-ring	EPDM
33	O-ring	NBR
34	Bolt	AISI 304 / 1.4301
35	O-ring	Viton
36	Compression fitting	AISI 304 / 1.4301

* Available spare parts.

a) Only for versions with self-relieving option.

Remarks: FDA / USP Class VI seals certificate on request.

All valves have a serial number. In case of non-standard valves, this number must be supplied if spare parts are ordered.

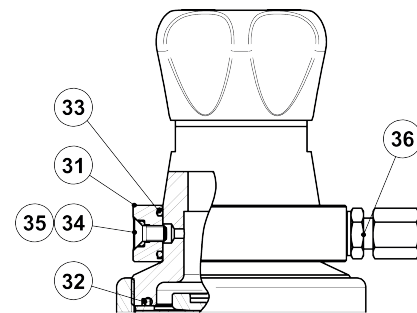
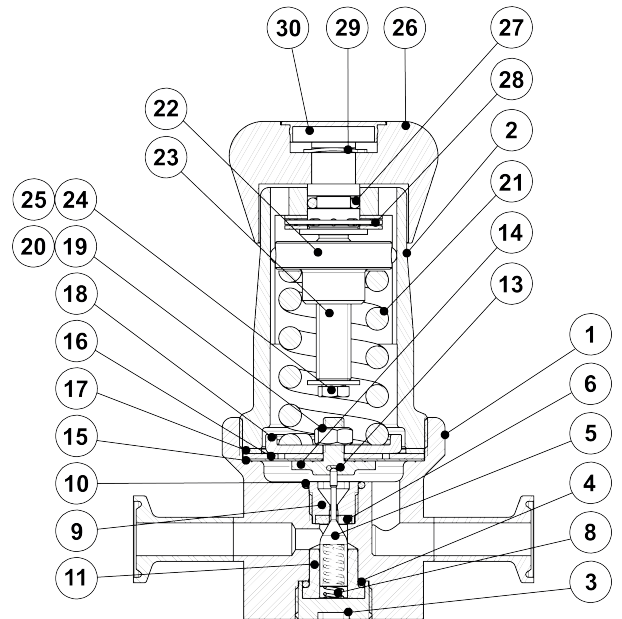

Leakage line / Captured vent option

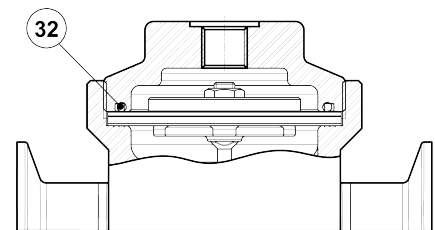

Dome-loaded top

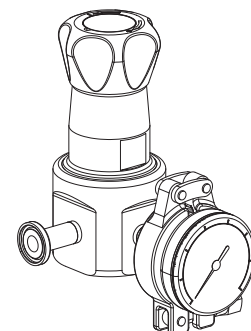

Optional pressure gauge connection.

ORDERING CODES P130L

Valve model	P3L	1	3	T	T	X	I	X	X	X	D	08	E
P130L – AISI 316L / 1.4404 diaphragm sensing pressure reducing valve	P3L												
Regulating range													
0,2 to 1,5 bar		1											
0,3 to 3 bar		2											
2 to 8 bar		3											
0,2 to 8 bar (dome-loaded) a)		A											
Flow rate coefficient													
Kvs 0,06		3											
Kvs 0,19		6											
Kvs 0,25		7											
Diaphragm													
PTFE (Gylon)				T									
EPDM (non-standard)				E									
Seat material													
TFM 1600					T								
EPDM					E								
Relieving													
Non-relieving b)						X							
Relieving (only for non-dangerous gases)						R							
Relieving with captured vent						L							
Adjustment knob and top cap													
Stainless steel adjustment knob							I						
Nylon adjustment knob							P						
Top cap (adjustment screw with cover)							T						
Dome-loaded top b)							X						
Gauge port options													
Without gauge ports								X					
Tri-clamp gauge port on the left side (rel. to the flow direction) – downstream pressure									7				
Tri-clamp gauge port on the right side (rel. to the flow direction) – downstream pressure										6			
Tri-clamp gauge port on both sides – downstream pressure											5		
Threaded gauge port on the left side (rel. to the flow direction) – downstream pressure – ISO 7 Rp 1/4"												4	
Threaded gauge port on the right side (rel. to the flow direction) – downstream pressure – ISO 7 Rp 1/4"													3
Threaded gauge port on both sides – downstream pressure – ISO 7 Rp 1/4"													2
Threaded gauge port on the left side (rel. to the flow direction) – downstream pressure – 1/4" NPT													W
Threaded gauge port on the right side (rel. to the flow direction) – downstream pressure – 1/4" NPT													Y
Threaded gauge port on both sides – downstream pressure – 1/4" NPT													Z
Surface finish c)													
Standard surface finish												X	
Mirror mechanical polished external surfaces (SF1)													P
Electropolished internal wetted parts (SF5)													E
Special features													
None												X	
Degreased for oxygen													O
Pipe connection													
Clamp ferrule ASME BPE													D
Clamp ferrule DIN (DIN 32676-A)													F
Clamp ferrule ISO (DIN 32676-B)													E
Tube weld (ETO) according to ASME BPE													DI
Tube weld (ETO) according to DIN 11866-A (DIN 11850-2)													FI
Tube weld (ETO) according to DIN 11866-B (ISO 1127)													EI
Size													
DN 08													08
DN 10													10
1/2" or DN 15													15
3/4" or DN 20													20
Special valves / Extras													
Full description or additional codes have to be added in case of non-standard combination													E

a) The loading control pressure can be up to a maximum of 1,2 bar above the required downstream pressure; **b)** These options must be chosen in case of dome-loaded version; **c)** Consult IS PV20.00 for further details and other surface finish options.