

## SANITARY PRESSURE SUSTAINING VALVE PS173

### DESCRIPTION

The ADCA PS173 series direct acting, spring-loaded diaphragm sensing, pressure sustaining valves are designed for use with clean steam, compressed air, water and other gases or liquids compatible with the construction materials.

### MAIN FEATURES

Compact inline design.  
Completely machined from bar stock material, no castings or forgings are used on the standard version.  
Non-rising adjustment knob.

### STANDARD SURFACE FINISH

Internal wetted parts:  $\leq 0,51$  micron Ra – SF1.  
External:  $\leq 0,76$  micron Ra – SF3.  
Other surface conditions see IS PV20.00 E – Technical information.  
Ultrasonic cleaning.

**OPTIONS:** Leakage line connection 1/8" (captured vent).  
Different soft valves for liquids and gases.  
Gauge connection on body.  
Bottom cover with drain connection.

**USE:** Clean steam, compressed air, water and other gases and liquids compatible with the construction.

**AVAILABLE MODELS:** PS173 – inline design.

**SIZES:** 1 1/2" to 2" ; DN 32 to DN 50.

**REGULATING RANGES:** 0,8 – 1,5 bar; 1 – 3 bar; 1,5 – 8 bar.

**CONNECTIONS:** ASME BPE, DIN and ISO clamp ferrules.  
Others on request.

**PACKAGING:** Assembling and packaging in a clean room certified according to ISO 14644-1.  
The product is end capped and sealed with recyclable thermo-shrinkable plastic film, to avoid contamination.

**INSTALLATION:** Horizontal installation.  
See IMI – Installation and maintenance instructions.



LIMITING CONDITIONS	
Valve model	PS173
Body design conditions	PN 16
Maximum upstream pressure	8 bar
Minimum upstream pressure	0,8 bar
Maximum design temperature *	150 °C

\* Others on request.

CE MARKING – GROUP 2 (PED – European Directive)	
PN 16	Category
1 1/2" to 2" – DN 32 to DN 50	SEP

**FLOW RATES COEFFICIENTS (m³/h)**

SIZE	ASME BPE		DIN		ISO	
	1 1/2"	2"	DN 40	DN 50	DN 32	DN 40
Kvs	5,5	8,5	5,5	8,5	5,5	8,5

**DIMENSIONS (mm) ASME BPE**

SIZE	A	B	B1	C	D	d1	d2	E	F	H	NPS 1/2"		WGT. (kg)
											F1	H1	
1 1/2"	170	94	70	199	130	25	15,75	90	50,5	34,8	25	9,4	8,6
2"	170	99	76	205	130	25	15,75	90	64	47,5	25	9,4	8,9

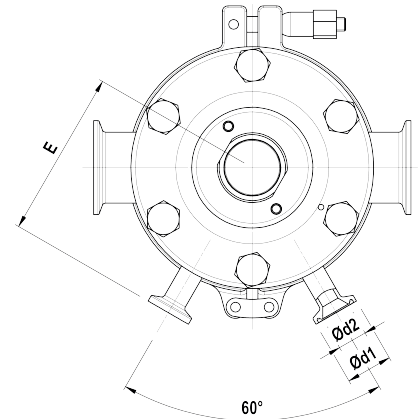

**DIMENSIONS (mm) DIN**

SIZE	A	B	B1	C	D	d1	d2	E	F	H	DN 15		WGT. (kg)
											F1	H1	
DN 40	170	94	70	199	130	25	15,75	90	50,5	38	34	10	8,6
DN 50	170	99	76	205	130	25	15,75	90	64	50	34	10	8,9

Remarks: Clamp ferrules according to DIN 32676-A;  
 Tube weld (ETO) according to DIN 11866-A (DIN 11850-2).

**DIMENSIONS (mm) ISO**

SIZE	A	B	B1	C	D	d1	d2	E	F	H	DN 15		WGT. (kg)
											F1	H1	
DN 32	170	93	70	199	130	25	15,75	90	64	38,4	25	10,3	8,6
DN 40	170	99	76	205	130	25	15,75	90	64	44,3	25	10,3	9,2

Remarks: Clamp ferrules according to DIN 32676-B;  
 Tube weld (ETO) according to DIN 11866-B (ISO 1127).

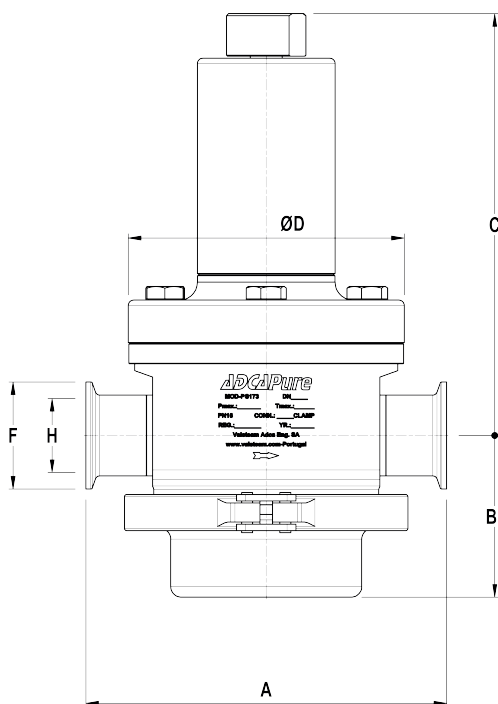

Valve without bottom connection.

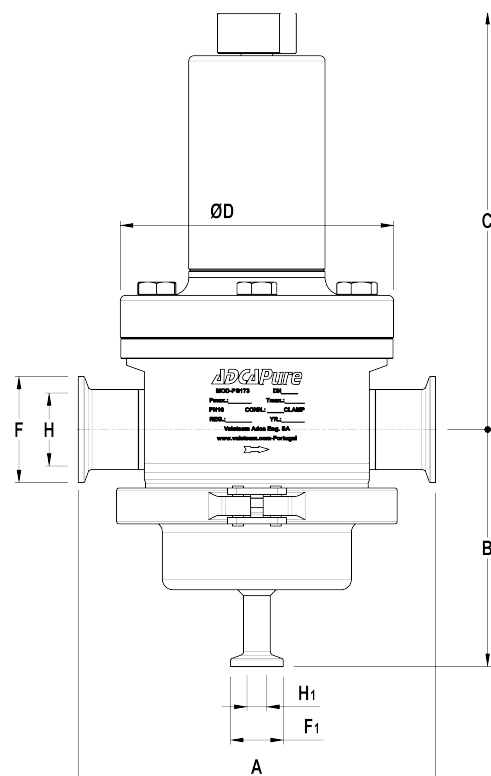

Valve with bottom connection for condensate drainage.

**MATERIALS**

POS. N°	DESIGNATION	MATERIAL
1	Valve body	AISI 316L / 1.4404
2	Cover	AISI 316L / 1.4404
2.1	Bottom cover	AISI 316L / 1.4404
2.2	Gasket	PTFE / TFM® Envelope gasket
2.3	Safety clamp	AISI 316 / 1.4401
3	Centering plate	AISI 316L / 1.4404
4	* Valve stem	AISI 316L / 1.4404
5	* Soft plug	EPDM; PTFE **
6	* Valve plug	AISI 316L / 1.4404
7	* Upper diaphragm	EPDM
8	* Lower diaphragm	PTFE (Gylon)
9	Diaphragm plate	AISI 316L / 1.4404
10	* O-ring	EPDM
11	Diaphragm plate	AISI 316L / 1.4404
12	Stem guide	AISI 316 / 1.4401
13	Spring plate	AISI 316 / 1.4401
14	Nut	Stainless steel A2-70
15	Washer	AISI 316 / 1.4401
16	* Adjustment spring	AISI 302 / 1.4300
17	Top spring plate	AISI 316 / 1.4401
18	Retaining washer	Stainless steel A2-70
19	Adjustment nut	AISI 316L / 1.4404
20	Adjustment screw	Brass
21	O-ring	NBR
22	Bearing	Corrosion resistant steel
23	Ext. bowed shaft ring	Stainless steel
24	Cover nut	Plastic
25	Bolts	Stainless steel A2-70

\* Available spare parts; \*\* Others according to fluid.  
FDA / USP Class VI seals certificate on request.  
For viton diaphragm the only approval available is the FDA (pos. 7).

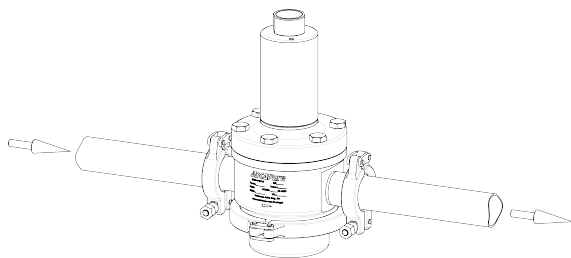
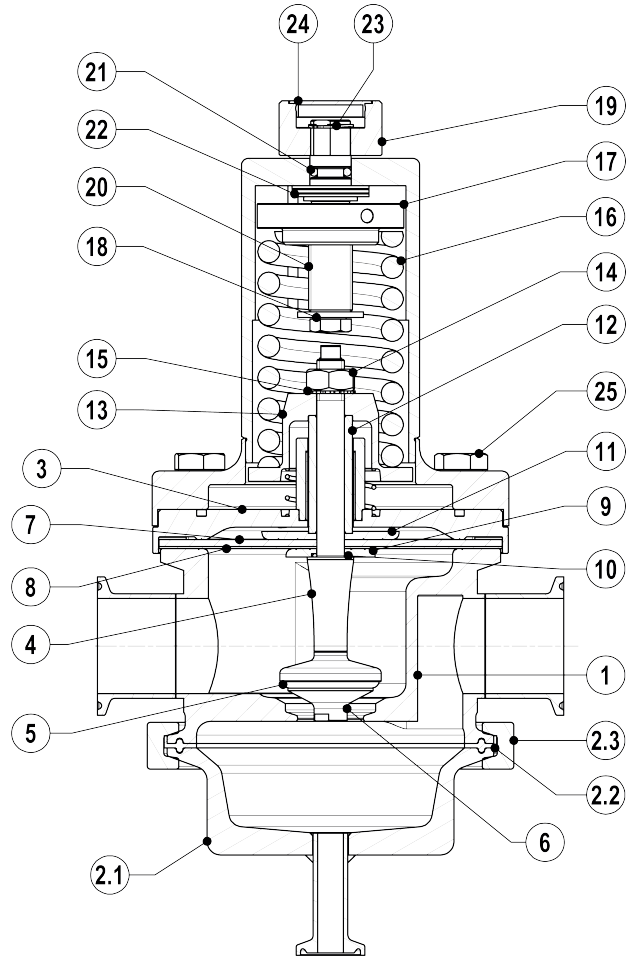

Valve without bottom drain, for clean gases.

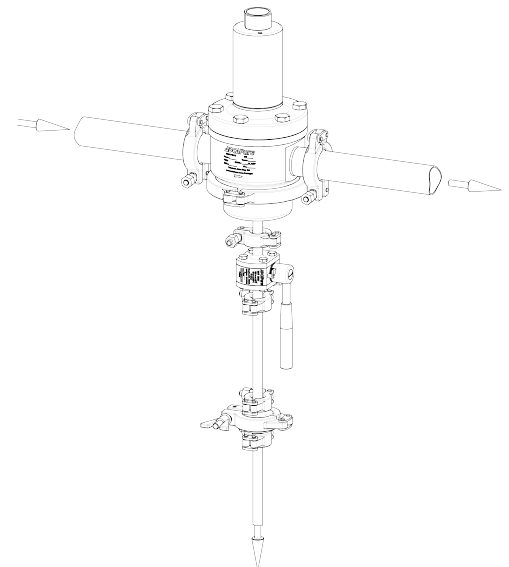

Valve with condensate drain for clean steam.

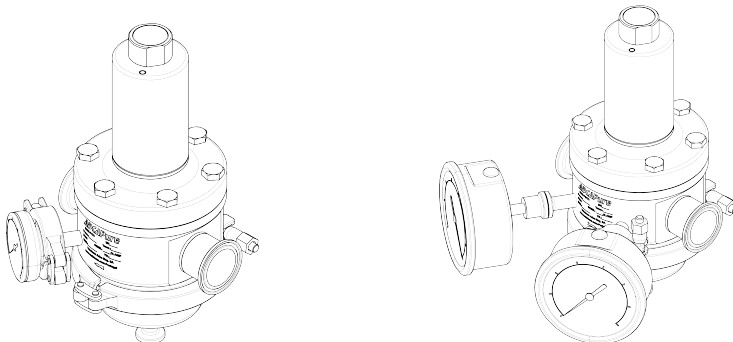

Optional pressure gauge connections.

ORDERING CODES PS173

Valve model	PS17D	4	4	T	M	I	X	X	X	DI	32
PS173 – AISI 316L / 1.4404 diaphragm sensing pressure sustaining valve with drain	PS17D										
PS173 – AISI 316L / 1.4404 diaphragm sensing pressure sustaining valve without drain	PS17										
<b>Regulating range</b>											
0,8 to 1,5 bar		4									
1 to 3 bar		5									
1,5 to 8 bar		7									
<b>Flow rate coefficient</b>											
Kvs 5,5		4									
Kvs 8,5		6									
<b>Diaphragm</b>											
PTFE (Gylon)				T							
EPDM (non-standard)				E							
<b>Seat material</b>											
Metal to metal (non-standard)					M						
EPDM					E						
PTFE					T						
FPM / Viton					V						
<b>Adjustment knob and top cap</b>											
Stainless steel adjustment knob						I					
Top cap (adjustment screw with cover)						T					
Stainless steel adjustment knob w/ diaphragm cover leakage connection in case of diaphragm failure						L					
Top cap (adjustment screw with cover) w/ diaphragm cover leakage connection in case of diaphragm failure						U					
<b>Gauge port options</b>											
Without gauge ports								X			
Tri-clamp gauge port on the left side (rel. to the flow direction) – downstream pressure – 1 connection								7			
Tri-clamp gauge port on the right side (rel. to the flow direction) – downstream pressure – 1 connection								6			
Tri-clamp gauge port on the left side (rel. to the flow direction) – upstream and downstream press. – 2 conn. a)								9			
Tri-clamp gauge port on the right side (rel. to the flow direct.) – upstream and downstream press. – 2 conn. a)								8			
Tri-clamp gauge port on both sides – downstream pressure – 2 connections								5			
Threaded gauge port on the left side (rel. to the flow direction) – downstream pressure – ISO 7 Rp 1/4"								4			
Threaded gauge port on the right side (rel. to the flow direction) – downstream pressure – ISO 7 Rp 1/4"								3			
Threaded gauge port on left side (rel. to the flow direction) – upstream and downstream press. – 2 conn. – ISO 7 Rp 1/4"								1			
Threaded gauge port on right side (rel. to the flow direction) – upstream/downstream pressure – 2 conn. – ISO 7 Rp 1/4"								0			
Threaded gauge port on both sides – downstream pressure – ISO 7 Rp 1/4"								2			
Threaded gauge port on the left side (rel. to the flow direction) – downstream pressure – 1/4" NPT								W			
Threaded gauge port on the right side (rel. to the flow direction) – downstream pressure – 1/4" NPT								Y			
Threaded gauge port on left side (rel. to the flow direction) – upstream and downstream press. – 2 conn. – 1/4" NPT								U			
Threaded gauge port on right side (rel. to the flow direction) – upstream and downstream pressure – 2 conn. – 1/4" NPT								V			
Threaded gauge port on both sides – downstream pressure – 1/4" NPT								Z			
<b>Surface finish b)</b>											
Standard surface finish									X		
Mirror mechanical polished external surfaces (SF1)									P		
Electropolished internal wetted parts (SF5)									E		
<b>Special features</b>											
None										X	
Degreased for oxygen										O	
<b>Pipe connection</b>											
Clamp ferrule ASME BPE											D
Clamp ferrule DIN (DIN 32676-A)											F
Clamp ferrule ISO (DIN 32676-B)											E
Tube weld (ETO) according to ASME BPE											DI
Tube weld (ETO) according to DIN 11866-A (DIN 11850-2)											FI
Tube weld (ETO) according to DIN 11866-B (ISO 1127)											EI
<b>Size</b>											
DN 32 (available with ISO connections only)											32
1 1/2" or DN 40											40
2" or DN 50 (not available with ISO connections)											50
<b>Special valves / Extras</b>											
Full description or additional codes have to be added in case of non-standard combination											E

a) Under special request and after approval of technical solution; b) Consult IS PV20.00 for further details and other surface finish options.