



I Application

The INNOVA F valve is a shut-off single seat valve designed specifically for installation at the tank bottom for use in hygienic applications.

I Design and features

- More compact space-saving design.
- Specific body with a welded flange.
- 45° elbow outlet to enable welding.
- Opening towards the inside of the valve.
- Radial type seal design.
- Single-acting actuator.
- Normally closed valve.
- Open lantern allows visual inspection of shaft sealing.

I Technical specifications

Materials:

Parts in contact with the product	AISI 316L (1.4404)
Other stainless steel parts	AISI 304 (1.4301)
Gasket	EPDM

Surface finish:

Internal	Bright polish Ra ≤ 0,8 µm
External	Matt

Available sizes:

DIN 11850	DN 25 - DN 100
ASME BPE	OD 1" - OD 4"

Connections:

Weld

Operating limits:

Temperature range	-10 °C to +121 °C (EPDM)	14 °F to 250 °F
SIP, max. 30 min	+140 °C	284 °F
Maximum working pressure	10 bar	145 PSI
Minimum working pressure	Vacuum	Vacuum
Compressed air pressure	6-8 bar	87-116 PSI

I Options

- Manual actuator.
- Gaskets: FPM, HNBR.
- Other connection types.
- C-TOP and C-TOP+ control units.
- External position sensors.
- Surface finish: Ra ≤ 0,5 µm.



I Housing combinations

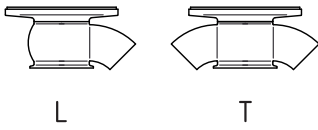

I Dimensions

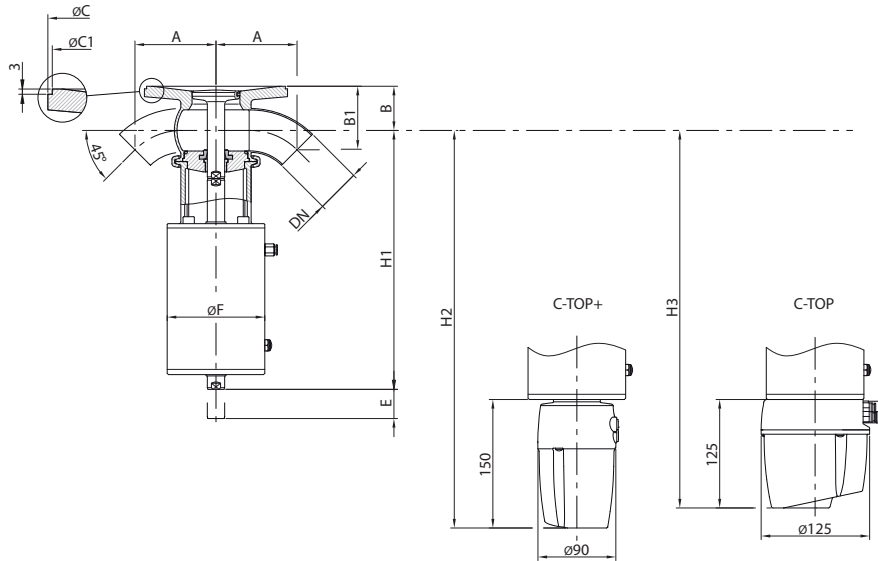

	DN	Pipe Ø	A	B	B1	Ø C	Ø C1	Ø F	E	H1	H2	H3	kg
DIN	25	29 x 1,5	58	41	56	125	120	87	27	228	367	342	6,0
	40	41 x 1,5	75	45	63	155	150	87	27	238	377	352	7,0
	50	53 x 1,5	90	52	73	165	160	112	34	300	433	408	10
	65	70 x 2,0	110	63	86	195	190	143	40	346	485	460	18
	80	85 x 2,0	122	74	100	215	210	143	40	353	492	467	19
	100	104 x 2,0	141	87	116	255	250	216	36	380	516	491	36
OD	1"	25,4 x 1,65	51	39	50	125	120	87	27	226	365	340	6,0
	1½"	38,1 x 1,65	73	43	60	155	150	87	27	237	379	354	7,0
	2"	50,8 x 1,65	93	51	73	165	160	112	34	298	434	409	10
	2½"	63,5 x 1,65	121	60	88	195	190	143	40	343	488	463	18
	3"	76,2 x 1,65	140	69	103	215	210	143	40	349	496	471	20
	4"	101,6 x 2,11	178	85	130	255	250	216	36	379	517	492	37