



Direct mount  
of actuators

## MODU 22

2-pcs ball valve PN69

- Stainless steel "CF8M"
- Threaded connection BSPP
- Industrial 2-piece ball valve in high quality
- Possibility of direct actuator assembly
- Unique patented stem seal design that ensures long and trouble-free operation
- Glass fibre reinforced seats which increase temperature and wear resistance
- Made of from food-approved materials
- ISO 14001 certification



Make it better.

**MODU**<sup>®</sup>

# MODU 22

2-pcs ball valve PN69 • FDA, ATEX, TA-LUFT, EU1935

## Connection

Threaded connection BSPP female/female

## Usable for

Water, air, steam, oil ect.

## Options

Connection: Threaded NPT  
 Seat material: PTFE, Delrin, PEEK I.a  
 Dimensions: 2-1/2" to 4"

## Pressure rating

1/4" til 2" 69bar / 1000psi

## Temperature

-20° C to 180° C

## Accessories

- Closed stem extension, TA-Luft approved stuffing box "TSM"
- Closed stem extension, without stuffing box
- Position indication, handle operated (inductive or mechanic)
- Spring return safety handle

## Parts description, excerpt

Pos	Description .....	Material
1	Valve body .....	Stainless steel CF8M
4	Seat .....	PTFE

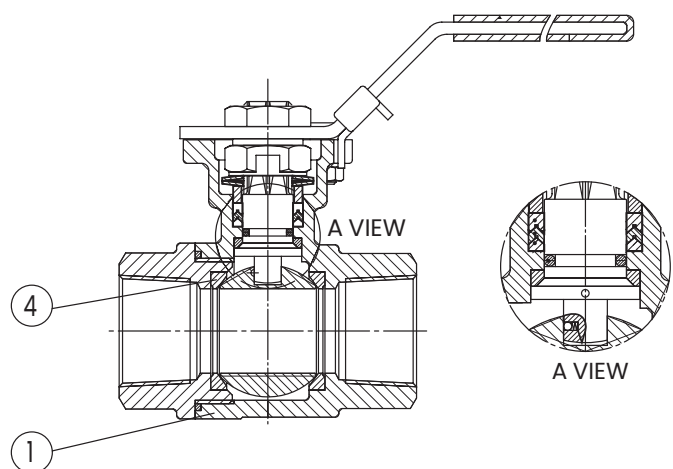

## Developed for your industry



Additional specification can be requested.

## Make it better.

MODU Valves A/S • moduvalves.com

### ➤ Improve the quality

We help Engineers to improve the quality of your manufacturing process.

### ➤ Optimize total cost

We help Purchasing Officers to optimize total cost of production, prevent downtime and safeguard your brand.

### ➤ Work smarter

We help Maintenance Crews to work smarter, while preventing time-consuming mistakes.

# MODU 22

2-pcs ball valve PN69 • FDA, ATEX, TA-LUFT, EU1935

## Materials

Pos	Description	Material
1	Valve body	Stainless steel CF8M
2	Threaded connection	Stainless steel CF8M
3	Ball	Stainless steel CF8M/AISI316
4	Seat	PTFE
5	Body gasket	PTFE
6	Stem gasket	RPTFE (25%Glas 75%PTFE)
7	Stem	Stainless steel AISI316
8	Stem packing V-rings	PTFE
9	Bushing	Stainless steel AISI304
10	Belleville washers	Stainless steel AISI301
11	Stem nut	Stainless steel AISI304
12	Handle	Stainless steel AISI304
13	Sleeve	Vinyl
14	Stem washer	Stainless steel AISI304
15	Spring washer	Stainless steel AISI304
16	Stop bolt	Stainless steel AISI304
17	Nut	Stainless steel AISI304
18	Upper stem seal	RPTFE (25%Glas 75%PTFE)
19	Locking plate	Stainless steel AISI304
20	Antistatic device	Stainless steel AISI316
21	O-ring	FPM
22	Locking washer	Stainless steel AISI304

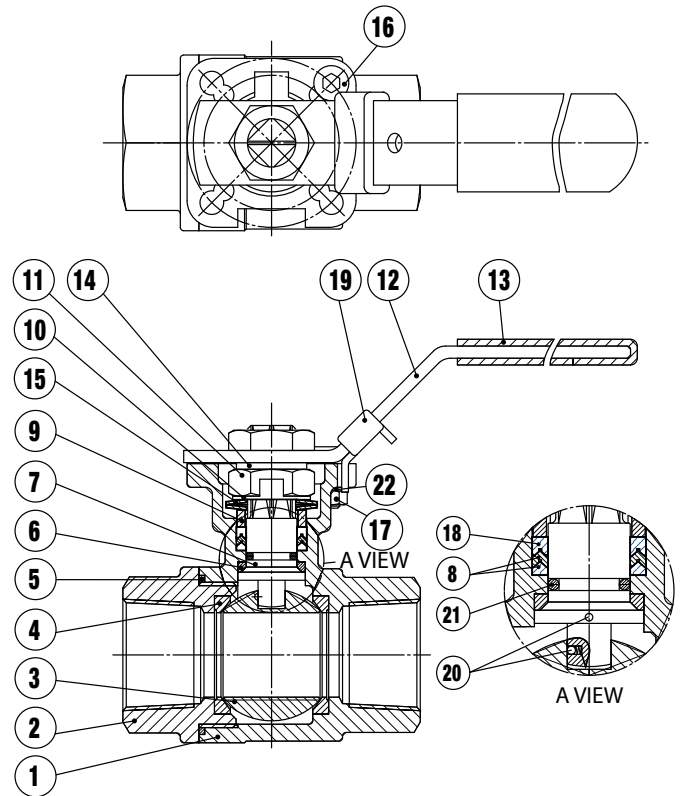

DIM Thread	*) Torque [Nm] Without pressure	Weight [kg]	Kv-vvalue [m³/t] FB 90°
1/4"	4.9	0.4	6
3/8"	4.9	0.4	7
1/2"	4.9	0.5	10
3/4"	5.6	0.6	27
1"	9.6	1.1	48
1 1/4"	11.2	1.5	70
1 1/2"	17.5	2.6	102
2"	23.2	3.6	204
2 1/2"	52	7.4	272
3"	81	10.4	493

\*) Torques are listed without safety factor at 20°C.  
See section below for actuator sizing

**Make it better.**

MODU Valves A/S • moduvalves.com

# MODU 22

2-pcs ball valve PN69 • FDA, ATEX, TA-LUFT, EU1935

## Dimension

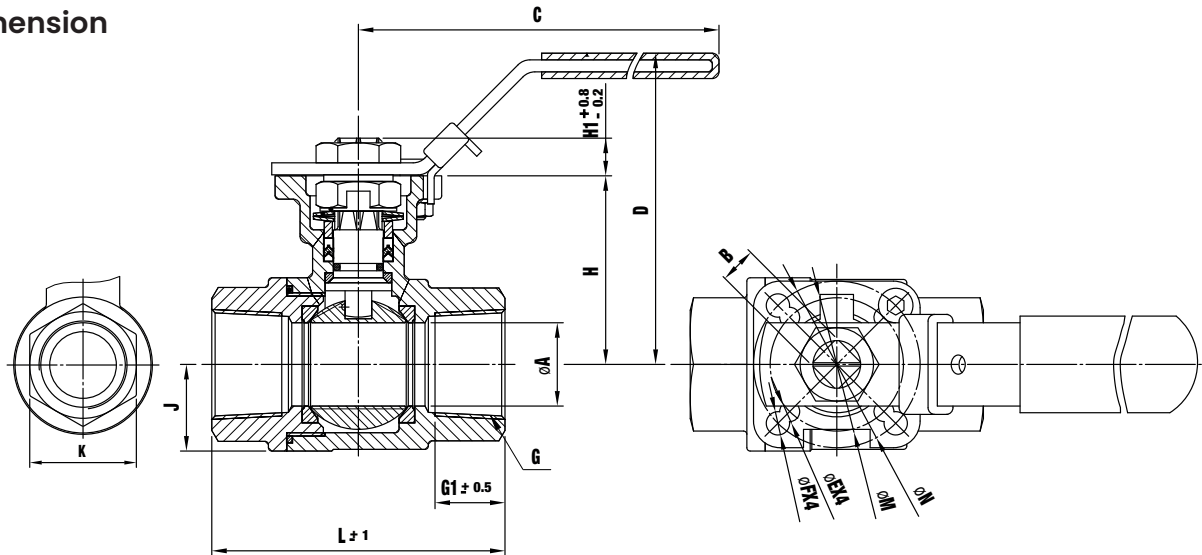

DIM	ØA	B	C	D	øE	øF	G	GI	H	HI	J	K	L	øM	øN	ISO5211
1/4"	11.5	9	139	74	6	6	BSPP	15.0	38.6	6.6	18.5	26	65.0	36	42	F03/F04
3/8"	12.5	9	139	74	6	6	BSPP	15.0	38.6	6.6	18.5	26	65.0	36	42	F03/F04
1/2"	15.0	9	139	74	6	6	BSPP	16.0	38.6	6.6	18.5	26	65.0	36	42	F03/F04
3/4"	20.0	9	139	82	6	6	BSPP	17.0	46.1	7.1	21.5	32	74.6	36	42	F03/F04
1"	25.0	11	165	96	6.5	7	BSPP	21.0	56.6	10.9	26.0	40	88.0	42	50	F04/F05
1 1/4"	32.0	11	165	100	6.5	7	BSPP	22.0	61.0	10.9	31.5	49	102.0	42	50	F04/F05
1 1/2"	38.0	14	215	127	7.5	9	BSPP	22.5	77.5	13.9	36.5	56	110.0	50	70	F05/F07
2"	50.0	14	215	134	7.5	9	BSPP	26.0	85.2	13.9	45.4	70	125.0	50	70	F05/F07
2 1/2"	65.0	17/19	263	167	10	12	BSPP	31.0	108.7	16.8	59	87	160.6	70	102	F07/F10
3"	65.0	17/19	313	175	10	12	BSPP	34.0	117.4	18.1	69.7	104	178.0	70	102	F07/F10

**Make it better.**

MODU Valves A/S • moduvalves.com

# MODU 22

2-pcs ball valve PN69 • FDA, ATEX, TA-LUFT, EU1935

## Temperature vs. pressure table for PTFE seats

Applicable to liquids and dry gases. For vaporous media, please contact MODU Valves A/S.

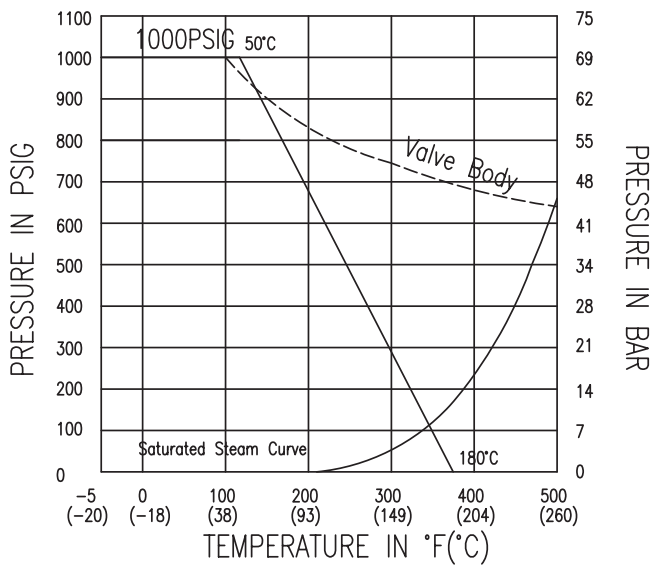

## Actuator sizing

Media factor	Multiply by
Clean, particle free, lubricating (oil, hydraulic fluids etc)	1.00
Clean, particle free, non-lubricating (water, alcohol etc)	1.20
Moist gas or saturated steam	1.20
Dry gas or superheated steam	1.40
Gas, dirty unfiltered i.e. Natural gas	1.50
Particle filled, corrosive, solvents and polluted systems	2.00 #

Service factor	Multiply by
Simple on / off maneuvering	1.00
Regulating / Throttling	1.20
Maneuvering once per week	1.20
Maneuvering every second week or critical component	1.50

For actuator dimensioning: Torque x Media factor x Service factor

# Polluted systems will reduce the expected life span of the seat rings