



Unique stuffing box
ensuring long and
reliable service

MODU 88

3-pcs ball valve PN125/100/69

- Stainless steel "CF8M" and Steel "WCB"
- 100% traceability - ProLog
- High quality industrial 3-pcs ball valve
- Closed pin blots for easy cleaning (up to 2-1/2")
- Unique stuffing box ensuring long and reliable service
- Carbon reinforced seats with superior temperature and wear resistance
- Direct mount of actuators
- Food grade materials used throughout the valve
- ISO 14001 certification

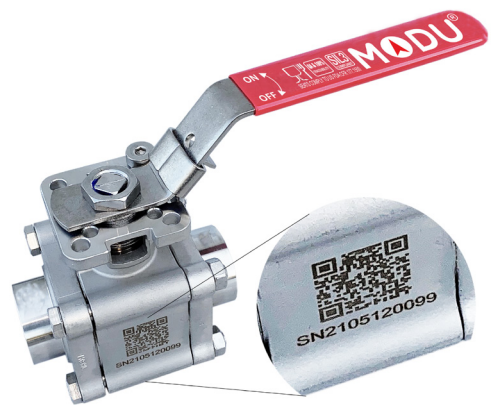

Make it better.

MODU[®]

MODU 88

3-pcs ball valve PN125/100/69 • EU1935/2004, FDA, Kosher, Halal ATEX, TA-LUFT, SIL3

Connections

Weld ends, ISO1127, SMS3008, EN12627 and BSPP threaded ends.

Usable for

Water, air, steam, oil etc.

Options (on request)

Body, end caps: Duplex, Hastelloy, Titanium
 Seat rings: PTFE, Delrin, PEEK i.a.
 Connections: NPT, ASME, ISO11850

Pressure rating

DN08F-DN40RB: 125bar / 2000psi
 DN40F-DN65RB: 100bar / 1500psi
 DN50F-DN100F: 69bar / 1000psi

Temperatur

-40°C to 250°C

Accessories

- V-port ball (30o, 60o, 90o), for regulating purposes
- Precision coupling / bracket regulating purposes
- Closed stem extension, TA-Luft approved stuffing box "TSM"
- Closed stem extension, without stuffing box
- Handle with position indication, lockable
- Position indication, handle operated (inductive or mechanic)

Parts description, excerpt

Pos	Description	Material
1	Body	Stainless Steel CF8M or WCB
4	Seat	CTFE (25%C 75%PTFE)

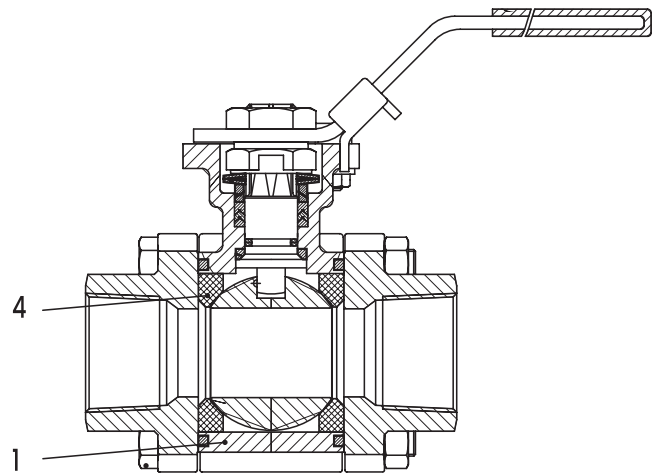

Developed for your industry



Additional specification can be requested.

Make it better.

MODU Valves A/S • moduvalves.com

➤ Improve the quality

We help Engineers to improve the quality of your manufacturing process.

➤ Optimize total cost

We help Purchasing Officers to optimize total cost of production, prevent downtime and safeguard your brand.

➤ Work smarter

We help Maintenance Crews to work smarter, while preventing time-consuming mistakes.

MODU 88

3-pcs ball valve PN125/100/69 • EU1935/2004, FDA, Kosher, Halal ATEX, TA-LUFT, SIL3

Materials

Pos *	Description.....	Material
1	SE Body.....	Stainless Steel CF8M or WCB
2	SE Connection.....	Stainless Steel CF3M or WCB
3	SE Ball.....	Stainless Steel CF8M / AISI316
4	SEF Seat.....	CTFE (25%C 75%PTFE)
5	EF Joint gasket.....	PTFE - TFM1600
6	EF Pyramid segment.....	CTFE (25%C 75%PTFE)
7	SEM Stem.....	Stainless Steel AISI316
8	EF Stem seal V-ring....	MG1241 (5%C 20%R 75%PTFE)
8.1	EF Stem seal top ring RTFE (25% Glas 75%PTFE)	
9	Gland.....	Stainless Steel AISI304
10	Lock saddle.....	Stainless Steel AISI304
11	M Nut.....	Stainless Steel AISI304
12	Handle.....	Stainless Steel AISI304
13	Sleeve.....	Vinyl
14	Washer.....	Stainless Steel AISI304
15	M Bolt.....	Stainless Steel AISI304
16	M Nut.....	Stainless Steel AISI304
17	Belleville washer	Stainless Steel AISI301
18	Stop bolt.....	Stainless Steel AISI304
19	Nut.....	Stainless Steel AISI304
20	Locking device	Stainless Steel AISI304
21	EF O-ring.....	FPM
22	E Antistatic device....	Stainless Steel AISI316
23	Spring.....	Stainless Steel AISI316
24	Spring ring.....	Stainless Steel AISI304
25	EF Grease.....	NLGI 2 food grade

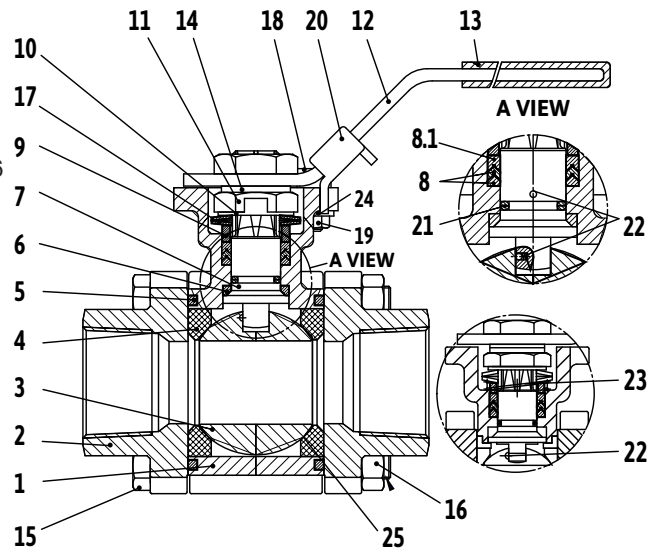

*Documentation 1-1 certificate on each valve

Each ball valve is serial numbered and covered by MODU's production log. This describes each individual body bolt as well as the tightening torque of the spindle nut. The torque of the ball valve is measured for final verification of the tolerance quality, which is all crucial for a uniform and correct actuator sizing. The production log can be viewed by scanning the valve's QR code and entering the serial number of the valve.

[S] 100% traceability - ProLog
The item is covered by heat number certificate and full traceability. The component will have a heat number embossed on the surface or be described under serial number in the production log. 3.1 material certificate for steel parts.

[E] The materials apply to declaration for food contact
EU-declaration no. 1935/2004
EU-declaration no. 10/2011
EU-declaration no. 2023/2006



[F] FDA 21 CFR

[M] Digital logging of tightening torques which are stored in the ball valve's production log as well as stem torque.

DIM		*) Torque [Nm]						Weight		Kv-value		Weld ends available as [R=Reduce bore] [F=Full bore]				
Weld	Thread	FB	FB	FB	RB	RB	RB	[kg]		[m ³ /t]		WCB EN 12627 ØG x T (ØD)	CF3M ISO 1127 ØG x T (ØD)	CF3M SMS3008** ØG x T (ØC)		
		10% Max bar	50% Max bar	100% Max bar	10% Max bar	50% Max bar	100% Max bar	FB	RB	FB90°	RB90°					
DN08	1/4"	6,9	6,9	7,7	-	-	-	0.89	-	6.9	-	14.0 x 2 (10.0)	F	13.5 x 1.6 (10.3)	F	-
DN10	3/8"	6,9	6,9	7,7	-	-	-	0.88	-	6.9	-	17.5 x 3.35 (11.4)	F	17.2 x 1.6 (14.0)	F	12.0 x 1.0 (11.5)
DN15	1/2"	6,9	6,9	10,0	6,9	6,9	7,7	0.82	0.84	12.7	6.9	21.7 x 3.35 (15.0)	R/F	21.3 x 1.6 (18.1)	R/F	18.0 x 1.0 (12.6)
DN20	3/4"	9,2	9,2	15,4	6,9	6,9	10,0	1.29	0.85	29.2	12.7	27.2 x 3.35 (20.5)	R/F	26.9 x 1.6 (23.7)	R/F	25.0 x 1,2 (15.0)
DN25	1"	13,1	13,1	20,0	9,2	9,2	15,4	2.01	1.41	48.2	29.2	34 x 4.15 (25.7)	R/F	33.7 x 2.0 (29.7)	R/F	25.0 x 1.2 (20.0)
DN32	1 1/4"	20,0	20,0	33,8	13,1	13,1	20,0	2.76	2.17	73.1	48.2	42.7 x 4.15(34.4)	R/F	42.4 x 2,0 (38.4)	R/F	32.0 x 1.2 (20,0)
DN40	1 1/2"	26,9	26,9	51,5	20,0	20,0	33,8	4.21	2.87	107.5	73.1	48.6 x 4.15(40.3)	R/F	48.3 x 2.0 (44.3)	R/F	38.0 x 1.2 (32.0)
DN50	2"	27,7	33,1	60,8	26,9	26,9	51,5	5.83	4.49	215.0	107.5	60.5 x 4.6 (51.3)	R/F	60.3 x 2.6 (55.1)	R/F	51.0 x 1.2 (38.0)
DN65	2 1/2"	52,3	83,8	141,5	27,7	33,1	60,8	11.00	6.94	275.2	215.0	76.3 x 4.6 (67.1)	R/F	76.1 x 2.6 (70.9)	R/F	63.5 x 1.6 (50.0)
DN80	3"	67,7	108,5	183,1	52,3	83,8	141,5	14.78	12.64	498.8	275.2	88.9 x 4.45 (80.0)	R/F	88.9 x 2.6 (83.7)	R/F	76.1 x 1.6 (65.0)
DN100	4"	87,7	167,0	254,6	67,7	108,5	183,1	23.30	16.00	877.2	498.8	116 x 6.45 (103.1)	R/F	114.3 x 2.6 (109.1)	R/F	101.6 x 2.0 (76.0)

*) Torques are listed without safety factor at 20°C. See section for actuator sizing in the following pages.

**) For SMS butt weld ends please refer to the bore (ØC) when reading the Kv-value. Ex. (Ø25x1,2 (15) = DN15F/20R)

Make it better.

MODU Valves A/S • moduvalves.com

MODU 88

3-pcs ball valve PN125/100/69 • EU1935/2004, FDA, Kosher, Halal ATEX, TA-LUFT, SIL3

Dimensions

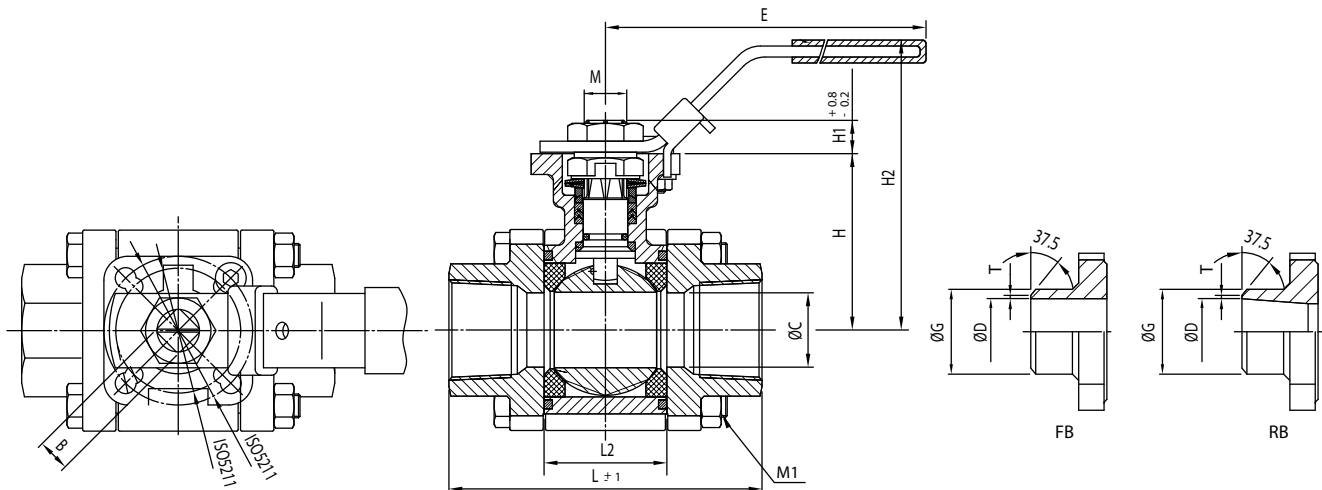

DIM	ØC [mm]		B [mm]		L [mm] BSPP		L [mm] ISO		L [mm] SMS		L2 [mm]		E [mm]		H [mm]	
	F	R	F	R	F	R	F	R	F	R	F	R	F	R	F	R
1/4"	11.5	-	9	-	75.0	-	75.0	-	-	-	24.5	-	139	-	42.6	-
3/8"	12.6	-	9	-	75.0	-	75.0	-	68.8	-	24.5	-	139	-	42.6	-
1/2"	15	12.6	9	9	72.5	75.0	75.0	75.0	75.0	75.0	24.5	24.5	139	139	42.6	42.6
3/4"	20	15	9	9	85.4	72.5	90.0	74.8	90.0	74.8	31.4	24.5	139	139	46.9	42.6
1"	25	20	11	9	105.3	85.4	110.0	89.8	110.0	89.8	41.3	31.4	165	139	59.3	46.9
1-1/4"	32	25	11	11	111.0	105.3	115.0	109.4	-	109.4	48.4	41.3	165	165	62.6	59.3
1-1/2"	38	32	14	11	127.3	111.0	130.0	114.4	-	114.4	56.3	48.4	215	165	79.0	62.6
2"	50	38	14	14	142.8	127.3	142.8	130.0	-	130.0	71.4	56.3	215	215	87.7	79.0
2-1/2"	65	50	17	14	185.0	145.0	185.0	145.0	-	145.0	86.6	71.4	300	215	108.7	87.7
3"	76	65	17	17	205.0	185.0	205.0	185.0	-	185.0	99.0	86.6	370	300	117.7	108.7
4"	100	80	17	17	240.0	205.0	240.0	205.0	-	205.0	127.0	99.0	370	370	133.7	117.7

DIM	H1 [mm]		H2 [mm]		M		ISO5211	
	F	R	F	R	F	R	F	R
1/4"	7.6	-	77.0	-	7/16"UNF	-	F03/F04	-
3/8"	7.6	-	77.0	-	7/16"UNF	-	F03/F04	-
1/2"	7.6	7.6	77.0	77.0	7/16"UNF	7/16"UNF	F03/F04	F03/F04
3/4"	8.6	7.6	82.0	77.0	7/16"UNF	7/16"UNF	F03/F04	F03/F04
1"	10.4	8.6	98.5	82.0	9/16"UNF	7/16"UNF	F04/F05	F03/F04
1-1/4"	10.4	10.4	102.0	98.5	9/16"UNF	9/16"UNF	F04/F05	F04/F05
1-1/2"	13.4	10.4	128.0	102.0	3/4"UNF	9/16"UNF	F05/F07	F04/F05
2"	13.4	13.4	137.0	128.0	3/4"UNF	3/4"UNF	F05/F07	F05/F07
2-1/2"	16.8	13.4	167.0	137.0	M24	3/4"UNF	F07/F10	F05/F07
3"	17.8	16.8	176.0	167.0	M24	M24	F07/F10	F07/F10
4"	16.8	17.8	192.0	176.0	M24	M24	F07/F10	F07/F10

Make it better.

MODU Valves A/S • moduvalves.com

MODU 88

3-pcs ball valve PN125/100/69 • EU1935/2004, FDA, Kosher, Halal ATEX, TA-LUFT, SIL3

Temperature vs. pressure table for CTFE seats

Valid for fluids and dry gasses. For steam and similar services, contact MODU Valves A/S.

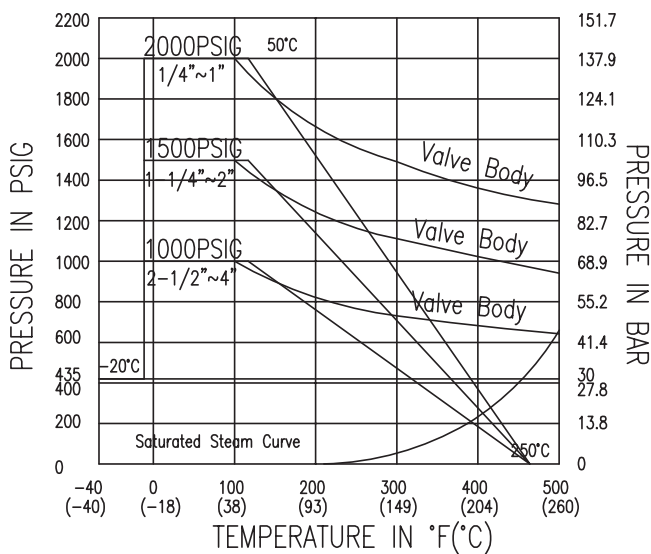

Actuator sizing

Media factor	Multiply by
Clean, particle free, lubricating (oil, hydraulic fluids etc)	1.00
Clean, particle free, non-lubricating (water, alcohol etc)	1.20
Moist gas or saturated steam	1.20
Dry gas or superheated steam	1.40
Gas, dirty unfiltered i.e. Natural gas	1.50
Particle filled, corrosive, solvents and polluted systems	2.00 #

Service factor	Multiply by
Simple on / off maneuvering	1.00
Regulating / Throttling	1.20
Maneuvering once per week	1.20
Maneuvering every second week or critical component	1.50

For actuator dimensioning:

Torque x Media factor x Service factor

Poluted systems will reduce the expected life span of the seat rings