



Spring-return
pneumatic actuator
air/spring

Venus SR

Pneumatic actuator

- SR, spring return - air/spring
- NBR -20 to 80°C
- High quality industrial pneumatic actuator
- Robust anodized aluminum casing / body
- ISO5211 connection
- VDI / VDE connection for position indication
- NAMUR connection for solenoid valves
- Mounted with plastic/metal indicator for inductive sensors
- Spring cartridges installed for mechanical failsafe function



Make it better.

MODU[®]

Venus SR

Pneumatic actuator • CE, ATEX, SIL III

General

Torque: 9 to 1.400Nm, at 6barg
 Supply: 2,5 to 10bar, ISO 8573-1 Class 3
 Connection: Namur and 2 pcs. 1/4" BSPP
 Adjustment: Open/close +/- 5°
 (-5...5° and 85...95°)

Usable for

Quarter-turn valves, i.e. butterfly valve, ball valves, dampers etc.

Options (on request)

Body/ends: PTFE coated, Epoxy coated
 Gaskets/o-rings: FPM (-15 to 150°C), Silicone (-35 to 80°C)
 Connection: Tongue / groove
 Rotation angle: 60°, 120°, 180°

Temperature

NBR -20 to 80°C

Accessories

- End-cover with extra long adjustment bolt (45°...95°)
- Electropneumatic positioner
- Mechanical limit switchbox
- Double inductive proximity sensor
- Solenoid valve, Namur 5/2, 24VDC / 230VAC
- Pneumatic air fittings, silencers, throttles
- Quick exhaust
- Various couplings and brackets in stainless steel for valve mounting

Parts description, excerpt

Pos	Description	Material
6	Body.....	Aluminum (6005-T5)
12	Pinion.....	Steel 45, nickel-plated

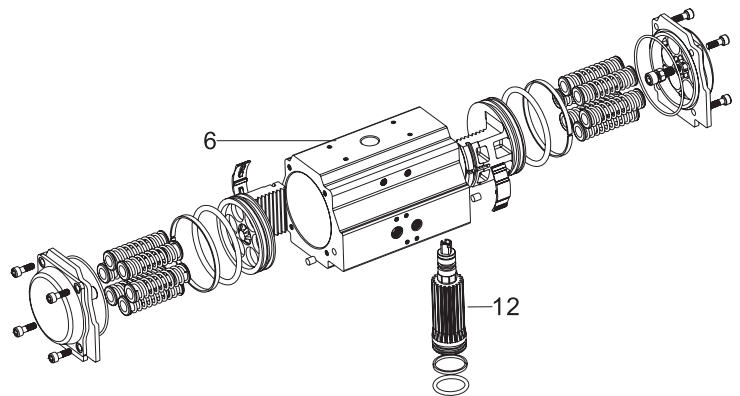

Spare parts

- Complete set of gaskets / kit
- Position indicator / puk

When / before ordering please identify the size of the actuator by looking at the label i.e. VENUS DA-63.

Developed for your industry



Additional specification can be requested.

Make it better.

MODU Valves A/S • moduvalves.com

➤ Improve the quality

We help Engineers to improve the quality of your manufacturing process.

➤ Optimize total cost

We help Purchasing Officers to optimize total cost of production, prevent downtime and safeguard your brand.

➤ Work smarter

We help Maintenance Crews to work smarter, while preventing time-consuming mistakes.

Venus SR

Pneumatic actuator • CE, ATEX, SIL III

Material

Pos	Description	Material
1	Indicator bolt	Stainless Steel AISI304/ABS
2	Indicator	Plastic (ABS) / AISI304
3	Circlip	Stainless Steel AISI304
4	Trust washer	Stainless Steel AISI304
5	Outside washer	POM
6	Body	Aluminum (6005-T5)
7	Guide	POM
8	O-ring	NBR
9	Bearing	POM
10	Inside washer	POM
11	Cam	Steel 45
12	Pinion	Steel 45, nickel-plated
13	Bearing	POM
14	O-ring	NBR
15	Spring	Spring steel
16	Bearing	POM
17	O-ring	NBR
18	Piston	Aluminum (A380)
19	Plug	NBR
20	O-ring	NBR
21	Nut	Stainless Steel AISI304 / A2
22	Adjust screw / bolt	Stainless Steel AISI304 / A2
23	Stop bolt	Stainless Steel AISI304 / A2
24	Stop nut	Stainless Steel AISI304 / A2
25	O-ring	NBR
26	End cap	Aluminum (A380)
27	Cap screw	Stainless Steel AISI304 / A2

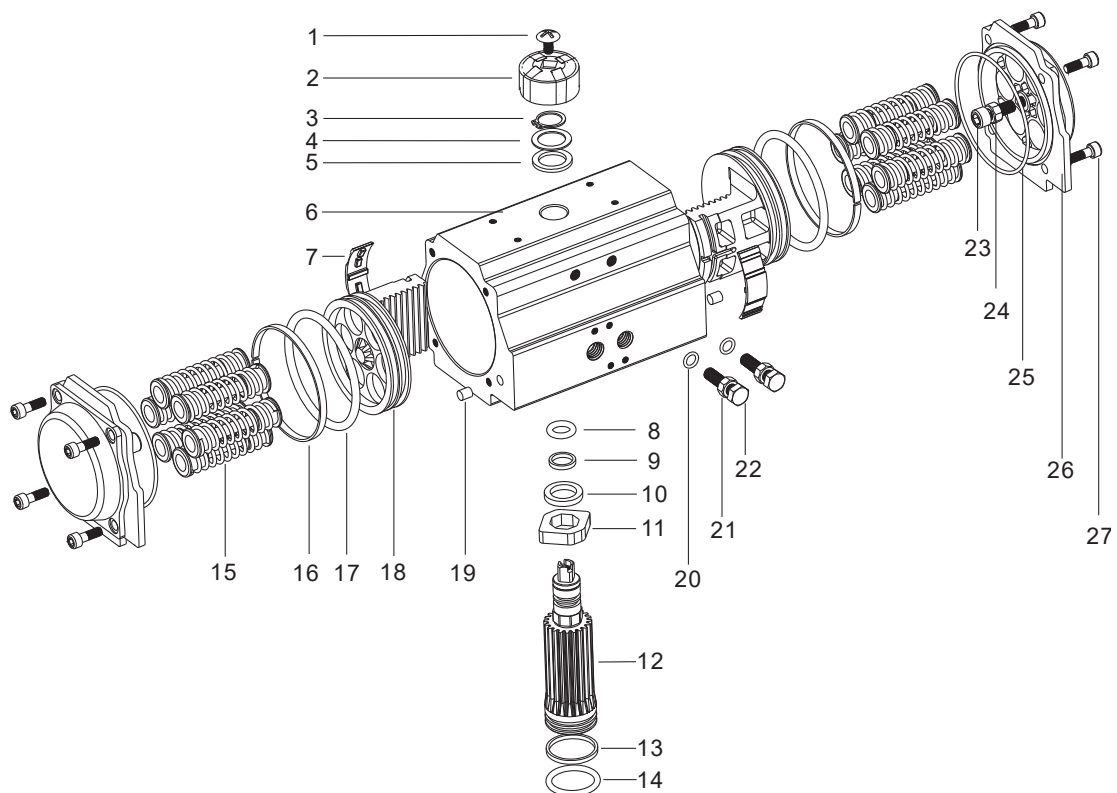

Venus SR

Pneumatic actuator • CE, ATEX, SIL III

Dimensions

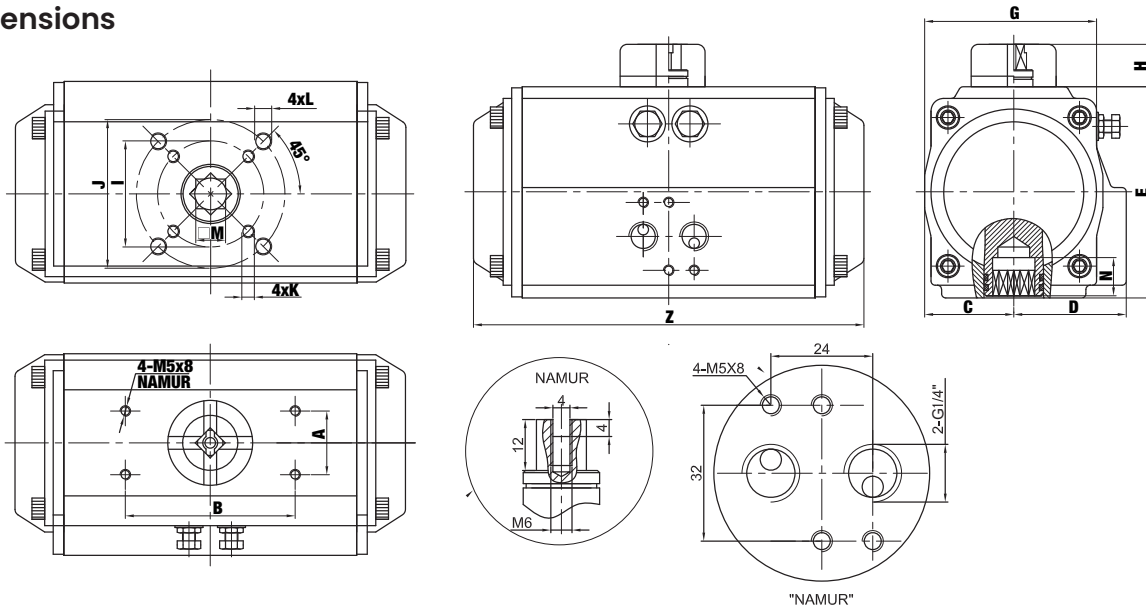

Model	A	B	C	D	E	G	H	I ISO5211	J ISO5211	K	L	M	N	Z	Connection
VENUS SR-52	30	80	30.0	41.5	72.0	65.0	20	Ø42 (F04)	-	M5x8	-	9	12	147	G1/4"
VENUS SR-52	30	80	30.0	41.5	72.0	65.0	20	Ø36 (F03)	Ø50 (F05)	M5x8	M6x10	11	14	147	G1/4"
VENUS SR-63	30	80	36.0	47.0	87.5	72.0	20	Ø42 (F04)	-	M6x10	-	9	12	168	G1/4"
VENUS SR-63	30	80	36.0	47.0	87.5	72.0	20	Ø36 (F03)	Ø50 (F05)	M5x8	M6x10	11	14	168	G1/4"
VENUS SR-75	30	80	42.0	53.0	99.5	81.0	20	Ø36 (F03)	Ø50 (F05)	M5x8	M6x10	11	14	184	G1/4"
VENUS SR-83	30	80	46.0	57.0	108.8	92.0	20	Ø50 (F05)	Ø70 (F07)	M6x10	M8x13	14	18	204	G1/4"
VENUS SR-92	30	80	50.0	61.0	116.5	98.0	20	Ø50 (F05)	Ø70 (F07)	M6x10	M8x13	17	18	262	G1/4"
VENUS SR-105	30	80	57.5	64.0	133.0	109.5	20	Ø70 (F07)	Ø102 (F10)	M8x13	M10x16	17	21	268	G1/4"
VENUS SR-125	30	80	67.5	74.5	155.0	127.5	20	Ø70 (F07)	Ø102 (F10)	M8x13	M10x16	17	21	301	G1/4"
VENUS SR-140	30	80	75.0	77.0	172.0	137.5	20	Ø102 (F10)	Ø125 (F12)	M10x16	M12x20	22	26	390	G1/4"
VENUS SR-160	30	80	87.0	87.0	197.0	158.0	20	Ø102 (F10)	Ø125 (F12)	M10x16	M12x20	22	26	458	G1/4"
VENUS SR-190	30	130	103.0	103.0	230.0	189.0	30	-	Ø125 (F12)	-	M12x20	27	31	528	G1/4"
VENUS SR-210	30	130	114.0	114.0	255.0	211.0	30	-	Ø140 (F14)	-	M16x25	27	31	532	G1/4"
VENUS SR-240	30	130	130.0	130.0	289.0	245.0	30	-	Ø165 (F16)	-	M20x25	36	40	602	G1/4"
VENUS SR-270	30	130	147.0	147.0	326.0	273.0	30	-	Ø165 (F16)	-	M20x25	46	50	722	G1/2"

Make it better.

MODU Valves A/S • moduvalves.com

Venus SR

Pneumatic actuator • CE, ATEX, SIL III

Torques

Model	Supply air [Bar] - Torques [Nm]										Weight KG	Air volume [L]		Cycle time [sec]**	
	5.0		6.0		7.0		8.0		Spring			Open	Closed	Open	Closed
	0° Closed	90° Open	0° Closed	90° Open	0° Closed	90° Open	0° Closed	90° Open	90° Open	0° Closed					
VENUS SR-52*	11.5	6.7	15.5	11.6	19.5	15.6	22.6	18.3	12.4	8.5	1.5	0.12	0.16	1.54	0.40
VENUS SR-63	20.0	11.4	27.3	18.6	34.6	25.9	41.9	33.3	25.0	16.4	2.2	0.21	0.23	1.66	0.44
VENUS SR-75	24.9	15.4	34.9	25.4	44.9	35.4	54.9	45.4	34.7	25.3	2.9	0.30	0.34	1.74	0.52
VENUS SR-83	40.4	23.2	56.1	38.9	71.7	54.5	87.4	70.2	55.2	38.0	3.6	0.43	0.47	1.83	0.61
VENUS SR-92	56.8	30.4	79.4	53.0	101.9	75.5	124.5	98.1	82.5	56.0	5.5	0.64	0.73	2.01	0.74
VENUS SR-105	89.4	47.5	122.5	80.6	155.5	113.6	188.6	146.7	118.1	75.9	7.8	0.95	0.88	2.26	0.79
VENUS SR-125	125	63	176	113	226	163	276	213	188	125	10,4	1.60	1.40	3.36	1.08
VENUS SR-140	221	118	307	203	392	289	478	374	310	206	14,4	2.50	2.20	3.68	1.22
VENUS SR-160	330	165	463	298	596	431	729	564	500	335	23.3	3.70	3.20	3.84	1.65
VENUS SR-190	584	322	797	535	1010	748	1223	960	742	480	46.1	5.90	5.40	4.83	3.40
VENUS SR-210	670	418	936	684	1202	950	1468	1216	912	660	53.2	7.50	7.50	7.50	4.50
VENUS SR-240	939	594	1323	979	1708	1363	2093	1748	1330	985	73.3	11.00	9.00	16.00	4.84
VENUS SR-270	1582	1037	2167	1623	2751	2207	3336	2792	1887	1342	115.9	17.00	14.00	17.40	6.14



Please make sure that the actuator torques at 90° (Open), and spring force at 0° (Closed) are sufficient to operate the valve.

Torques given at full spring package (12 springs)
 *VENUS SR-52 is equipped with 10 spring cartridges.
 **Based on 6 bar supply air pressure, no load on actuator. .