

## General Information

This manual shall serve as an instruction for installation and operation of MERKUR butterfly valves delivered by MODU Valves A/S. It is the responsibility of the installer to ensure that approved materials are used and that the installation and maintenance work meets applicable rules, regulations and requirements. In case of problems which cannot be solved from information in this manual, MODU Valves shall be contacted for support. Note that most of the information in this manual concerns safety, so please read carefully before installation of the valve.

## Storage

Store the valves indoors in a clean and dry place, without direct sunlight. Corrosion that occurs during storage will significantly reduce the life span of the valve. Butterfly valves shall be stored with the disc slightly opened to prevent permanent disc setting deformation of the liner.

## Handling

Be careful when lifting the valve. Never lift by the valve handle, gear operator or hand wheel. Securely place the rope or hoist around the valve or actuator body while handling.

## Installation precautions

The valves shall never be installed where service conditions could exceed the valve ratings concerning pressure, temperature or operating media. Failure to comply with this warning may result in personal injury or property damage.

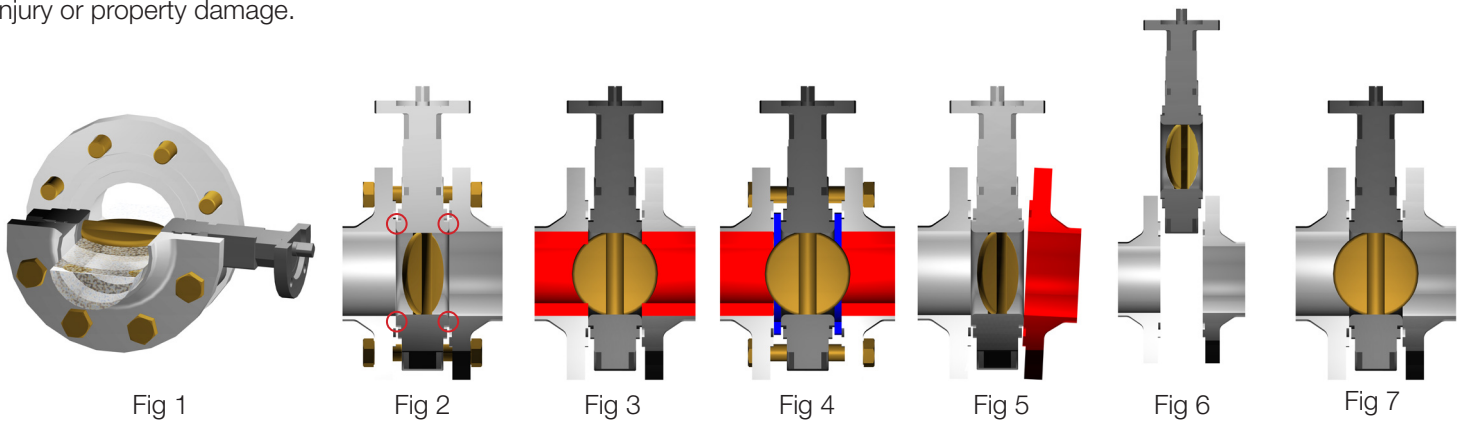
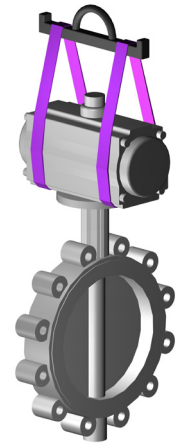

## Installation

MERKUR Wafer are suitable for installation between DIN PN10, PN16 and ANSI150 flanges.  
MERKUR LUG are suitable for installation between specific flanges due to fixed threaded holes.

- When installing a butterfly valve in a horizontal pipeline (Fig 1) it is recommended to mount the valve with disc rotation in horizontal plane as well. This installation form will minimize the settlement of sludge and particles around the turning points of the disc and shaft and help to clean the settlements of the pipeline, extending the lifespan of the valve. With that in mind it is however possible to mount the butterfly valve in any direction preferred.
- When mounting MERKUR butterfly valve (Fig 2) do not use any extra gaskets, the liner will suit as sealing against the flanges.
- Do not weld flanges with the butterfly valve installed as this may damage the liner.
- MERKUR butterfly valve may not be mounted between flanges with a nominal inner diameter smaller than the disc tip extending from the valve in open position (Fig 3). In such case use suitable spacers for installation (Fig 4).
- Flanges installed in the pipeline should be probably aligned to avoid damaging the butterfly valve or cause leakage (Fig 5).
- Distance between flanges shall allow easy installation on the butterfly valve without damaging the liner or surface (Fig 6).
- When tightening the bolts, to secure the valve, the disc should be slightly open. The bolts shall be tightened evenly cross wise to avoid local compression of the liner, which may lead to higher valve torque or leakage.

## Function test

- Always carry out functional test of the butterfly valve before putting into service. If used with an actuator please make sure that the travel stops of the actuator are probably adjusted. Insufficient adjustment of the actuator may cause internal leakage between disc and liner or increase the breakaway torque.

## Dismantling the butterfly valve

- Please always make sure that the line is depressurized before removing the valve from the pipeline. Dangerous fluid or gas may leak from the pipeline when removing the valve. Always wear proper protection in accordance with the medium.

## Spare parts

- MERKUR butterfly valves are designed to ensure a long life span, however it is possible to replace the liner of the valve. If spare parts are required, or you need a replacement valve, please consult MODU Valves A/S.

## Disposal

- Please always consider the environment when disposing a used butterfly valve which may contain toxins from the media.

## Maintenance

The butterfly valves have been designed and manufactured to obtain the maximum life and efficiency at minimum wear. Before starting any service jobs, make sure that the medium supply to the pipeline is cut off, pressure is decreased to ambient pressure, the pipeline is completely cleaned and ventilated and the plant is cooled down. Always keep safety instructions in mind and take all personal safety precautions. No periodic lubrication or maintenance is required.

During maintenance, the following rules should be observed:

- Always keep personal safety precautions in mind and always use appropriate protection e.g. clothing, masks, gloves etc.
- Be alert that the temperature still can be very high or low and can cause burns.
- Check the valve on all possible leaking possibilities.
- Check if all bolts and nuts, are still fastened.
- Dust, grease and medium residual, must be frequently cleaned of the valve body and all moving parts, such as stem to maintain all operating functions.

## Disassembly of MERKUR Butterfly valve

- Remove handle, manual gearbox or actuator from mounting flange.
- Open the valve and position the disc around 90 degree from the fully close position.
- Remove the lock ring (pos. 11) with correct tool.
- Pull out the stem from the body. Note - stem is of splined type
- With stem securely removed push/take out the disc
- With proper tools push out the liner, using evenly distributed pressure/force (bench press is preferred)
- If any part of the shaft or shaft bearings has been damaged, replace by new ones.

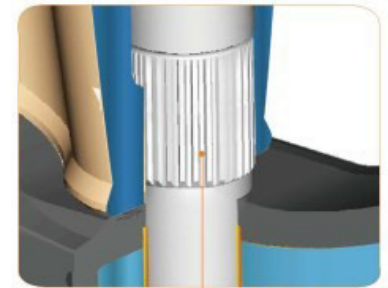

splined design

## Assembly of MERKUR Butterfly valve

- Align the stem holes of the new seat with the shaft holes in the valve.
- Push the new liner in place, using evenly distributed pressure/force (bench press is preferred)
- Insert the stem making sure the internal bushings (pos 8) are still in place then push the stem into the stem hole of the body until the bottom of the stem is flush with the inner top edge of the liner. Re-adjust the liner if not fully aligned with shaft/shaft hole.
- Make sure the groove on the stem top is positioned according to the disc position (90 degrees to close position)
- Install/align the disc in the same position as during dismounting (90 degrees to close position), Insert the disc, with the splined hole facing toward the top of the valve, into the seat by lining up the disc hole with the stem hole of the seat.
- With a downward pressure push the stem back and forth and rotating the disc, until the stem touches the bottom of the body stem hole. NOTE: be careful not to damage the splined connection.
- Mount the locking plate (pos 10)
- Mount the locking ring (pos 11)

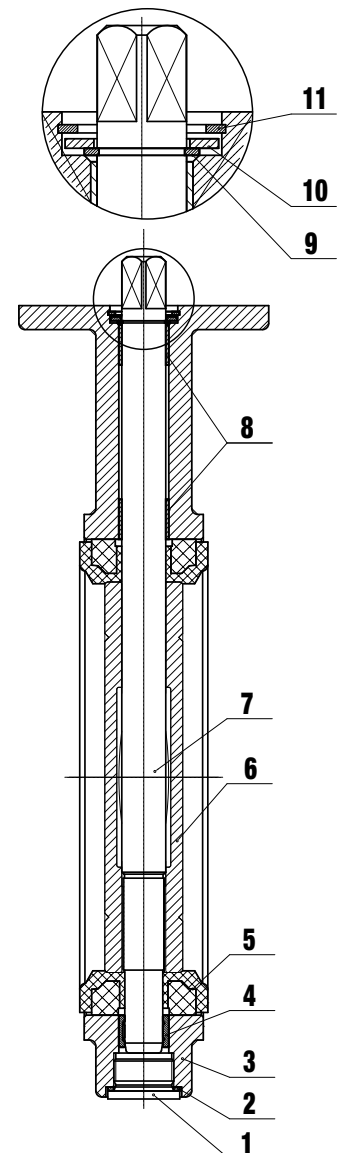

## Function test

It is recommended to perform a functional test before the butterfly valve is used for final operation. Hereby, the valve must be fully opened and closed to determine whether the valve runs smoothly and the flanges do not leak. If the pipe will be submitted to a pressure test the test pressure must not exceed the allowable operating pressure of the valve. Too high pressure may damage the valve.

## Service and repair

- All service and repair jobs should be carried out by authorized staff, using suitable tools and user shall use, bolt and nut of the same size and material as the original one.
- Welding (repair) and drilling of the butterfly valve is forbidden.
- Repair/overhaul of the valve is possible, but genuine parts must be used.
- During replacement of the butterfly valve, tighten the hexagon flange bolts (and nuts) evenly in crosswise order.
- After replacement of the butterfly valve, it is necessary to check the valve operation and tightness of all connections. A tightness test should be carried out.
- After installation, the valve should be checked and maintained periodically at least every 3 months, depending on the medium.