



# Piston Valves

YPG - YVN

Make it better.

**MODU**<sup>®</sup>

## Piston Valves

Piston Valves having long term experience on elastic sealing systems, designed piston valve by long term research activities. Lots of piston valves were used and are still in use in Turkey and all around the world. Main application areas are vapor, steam, water, heat transfer oils, high temperature hot water, thermal oil, chemical industry using corrosive fluids and food industry. realized the idea of replacing seat and plug with elastic sealing rings and cylindrical piston in globe valves. Our aim is to ensure customer satisfaction by manufacturing valves meeting expectations based on international standards and legal regulations.

### Application Examples



Piston valves can be used to control the flow of almost all kinds of fluids. Piston valves offers the optimum solutions. Valve body material may be cast iron, ductile iron, cast steel and stainless steel with appropriate sealing rings.



**Make it better.**

MODU Valves A/S • [moduvalves.com](http://moduvalves.com)



## Piston Valve – Working Principle

### Sealing System

Sealing system in the piston valve is enabled by a stainless steel piston and a couple of special elastic rings which surround the piston tightly. Sealing surface is the side surface of the piston. While upper ring provides sealing to atmosphere (outside), lower ring provides tightness in the line (inside).

Leakproofing is provided by tightness in the bonnet nuts acting axially to upper ring. The thrust is transmitted from upper ring to lower ring via lantern bushing. Special elastic rings are thereby compressed and transform this thrust into a radially acting pressure on the piston.

Elastic rings, being supported against the wall of the valve body, surround the cylindrical piston surface thereby result in an outstanding sealing. Layers of YX-GT rings press radially on the sealing surface of the piston. Belleville washers compensate the pressure and temperature changes. Thereby, a spontaneous and permanent sealing is provided by itself.

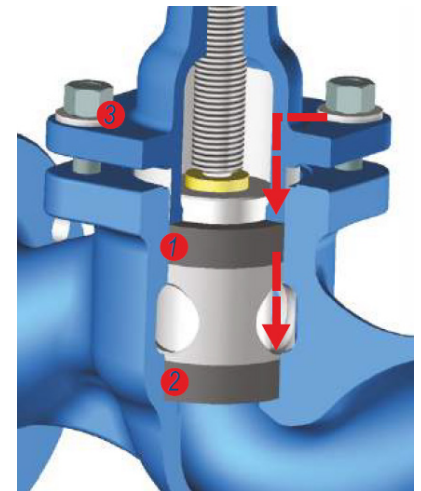

- 1 YX-GT upper ring
- 2 YX-GT lower ring
- 3 Belleville washer



Is not affected by unexpected materials flowing in the fluid. No corrosion on the leakproofing surface. There is no direct contact of the piston surface and the fluid. Therefore, there is no corrosion risk for the sealing surfaces. Only the bottom surface of the piston gets into contact with the fluid. This part is not related to the sealing performance.

Unexpected materials in the medium do not harm a piston valve. When the valve is being shut and the piston enters the lower ring, it sweeps out any particles of sand, welding globules and other impurities existing in the medium. The possibility of damage to the sealing system by abrasive matter existing in the fluid; a well-known problem with seat valves, is eliminated with the piston valves. Fibrous and contaminated media can be reliably shut off without trouble.

The piston valves of model YPG 15 to 50 have the same sealing system. There is no stuffing box with the ring. The balanced piston valves of model YVNB 65 to 200, have stuffing box with the ring. Easy operation is enabled thanks to pressure balance across the piston. Ring replacement takes short time, there is no need for difficult mechanical processes like seat grinding etc. for piston valves. A new valve is obtained just by replacing sealing rings. Since they are supported by stainless steel plate, rings have long service life.



No environmental contamination saves energy. Piston valves, providing an outstanding leaktightness across both to atmosphere and to line, prevent environmental contamination. Toxic fluids remain in the piping system and are not allowed to diffuse into atmosphere.

Piston valves save energy via preventing leakage of steam and other power transfer fluids to atmosphere.

**Make it better.**

MODU Valves A/S • moduvalves.com

**Piston Valves - YPG 15-50**

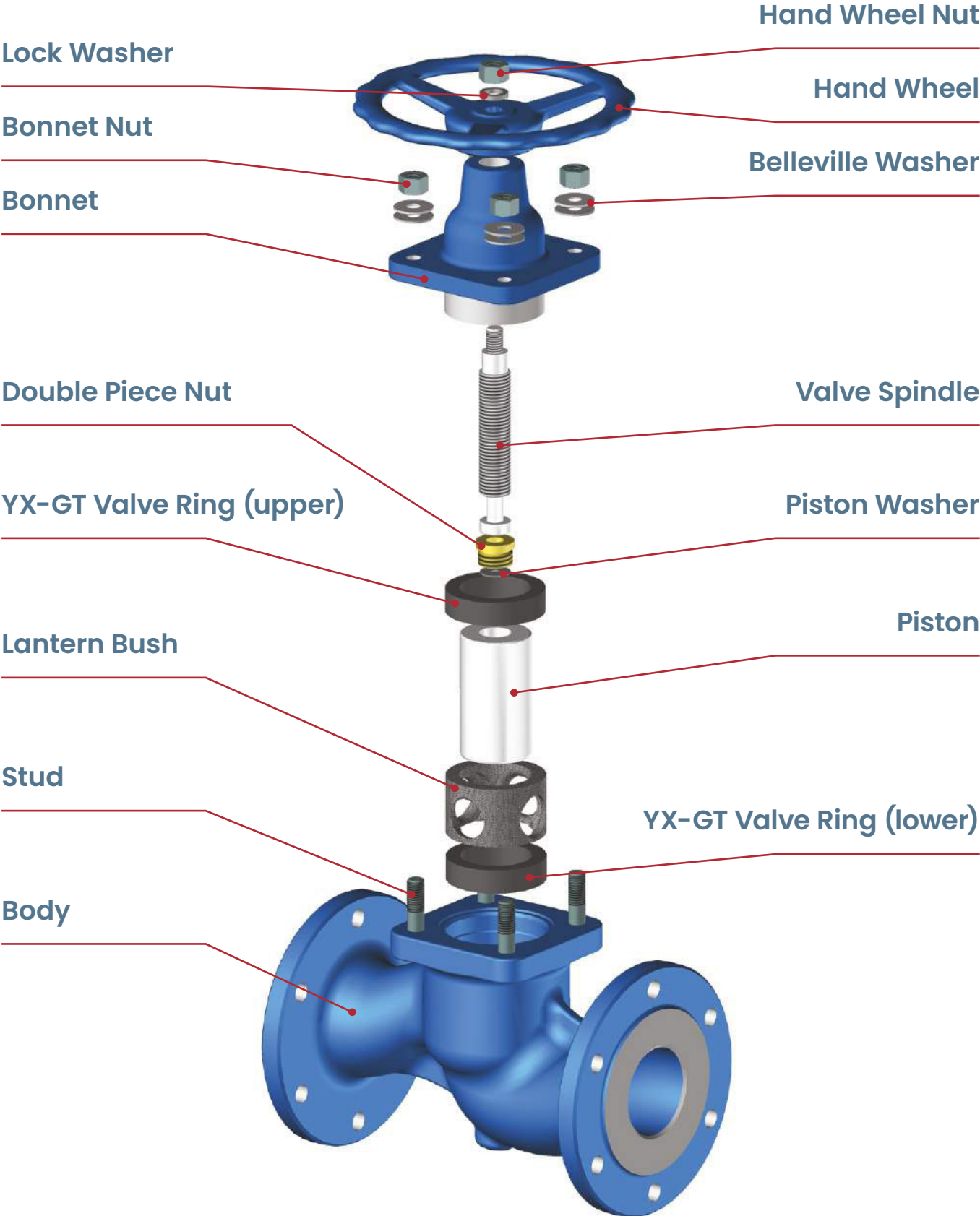

## Piston Valves – DNI5-50 – YPG Flanged

Material Type	Cast Iron	Ductile Iron	Cast Steel	Stainless Steel
Size	DNI5-50	DNI5-50	DNI5-50	DNI5-50
Pressure Class	PN16	PN25	PN40	PN40
Dimensions	DIN EN 558/1.serie	DIN EN 558/1.serie	DIN EN 558/1.serie	DIN EN 558/1.serie
Assembly	Flanged according to DIN EN 1092-2	Flanged according to DIN EN 1092-2	Flanged according to DIN EN 1092-1	Flanged according to DIN EN 1092-1
Temperature	-10°C +300°C	-10°C +350°C	-10°C +400°C	-10°C +400°C
Material Code	2	8	7	9
Order Code	YPG.2F.__.00	YPG.8F.__.00	YPG.7F.__.00	YPG.9F.__.00

### Fluid Types

All kinds of fluids such as water, hot water, high temperature hot water, steam, thermal oil, LPG, fuel oil, pressurized air, etc.

P.No	Part Name	Cast Iron	Ductile Iron	Cast Steel	St. Steel	St. Steel
1	Body	GJL 250	0.7040	1.0619	1.4308	1.4408
2	Upper Bonnet	GJL 250 ****	0.7040 ****	1.0619 ****	1.4308	1.4408
3	Hand Wheel	GJL 200	GJL 200	GJL 200	GJL 200	GJL 200
4	Piston	1.4021	1.4021	1.4021	1.4301	1.4401
5	Lantern Bush	GJL 200 + Phosphate	GJL 200 + Phosphate	GJL 200 + Phosphate	1.4308***	1.4408***
6	Valve Spindle	1.4021/St-42	1.4021/St-42	1.4021/St-42	1.4301	1.4401
7	Double Piece Nut	Ms-58	Ms-58	Ms-58	1.4301	1.4401
8	Valve Ring	Graphite	Graphite	Graphite	Graphite	Graphite
9	Nut	8.8+Gal.	8.8+Gal.	8.8+Gal.	A2-70	A2-70
10	Nut	8.8+Gal.	8.8+Gal.	8.8+Gal.	A2-70	A2-70
11	Stud	8.8+Gal.	8.8+Gal.	8.8+Gal.	A2-70	A2-70
12	Lock Washer	8.8+Gal.	8.8+Gal.	8.8+Gal.	A2-70	A2-70
13	Belleville Washer	50CrV4	50CrV4	50CrV4	A2-70	A2-70
14	Piston Washer	Ms-58	Ms-58	Ms-58	1.4301	1.4301

DN			Dimensions			Assembly size												
mm	inch	Type	L	H	A	D	g	Hole Nr.	k	PN16			PN25			PN40		
										b	f	l	b	f	l	b	f	l
15	1/2"	YVN 15	130	105	100	95	45	4	65	14	2	14	16	2	14	16	2	14
20	3/4"	YVN 20	150	120	120	105	58	4	75	16	2	14	18	2	14	18	2	14
25	1"	YVN 25	160	138	140	115	68	4	85	16	2	14	18	3	14	18	2	14
32	1 1/4"	YVN 32	180	154	160	140	78	4	100	18	2	19	18	3	19	18	2	18
40	1 1/2"	YVN 40	200	186	180	150	88	4	110	18	3	19	18	3	19	18	2	18
50	2"	YVN 50	230	211	200	165	102	4	125	20	3	19	20	3	19	20	2	18

\* For temperatures below -10°C, stud and nut material should be stainless steel.

\*\*\* 1.4401 for DNI5 and DN20.

\*\*\*\* Ck22 for DNI5 and DN20.

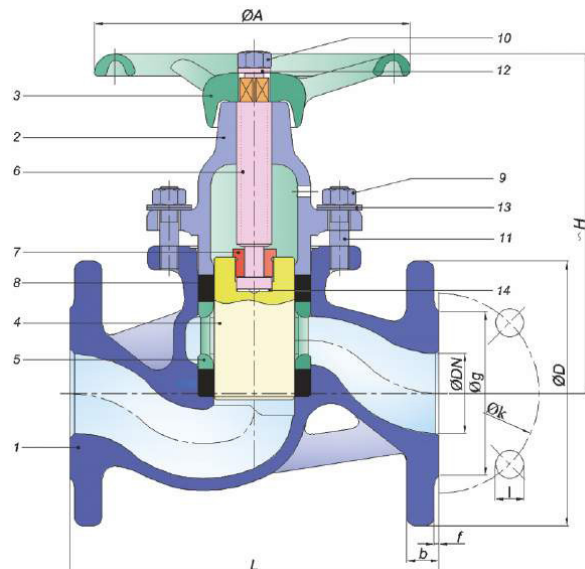

**Make it better.**

MODU Valves A/S • moduvalves.com

## Balanced Piston Valves

### Easy to operate

For balanced piston valves, top and bottom surfaces of the piston are in contact with fluid. So, pressure force is balanced to some extent on the piston. No counter pressure is exerted during release or shut off operation. Only the friction force contributes to release or shut off effort.

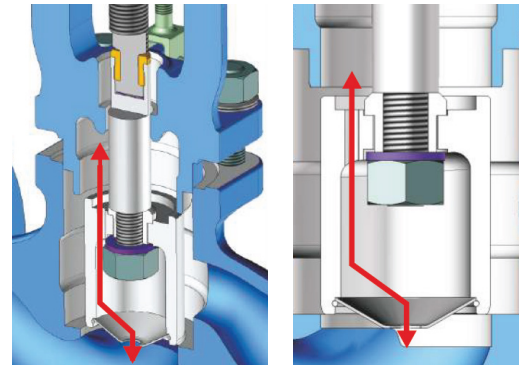

### Maintenance free

High temperature resistant Belleville washers, one located on the bonnet and the other located under the stuffing box nuts, create a constant thrust on the rings. This compensates pressure and temperature variations and avoids loosening due to abrasion. An outstanding maintenance free sealing is achieved for a long service life.



### Sealing System

- 1 **Spindle Sealing**  
The sealing between spindle and atmosphere is provided by stuffing box composed of 3 pieces of YX-GT rings.
- 2 **Body Sealing**  
The sealing between body and atmosphere is provided by 1 piece of YX-GT ring located between body and bonnet.
- 3 **Inner Sealing**  
The inner sealing is provided by 2 pieces of specially manufactured YX-GT rings surrounding the piston elastically.

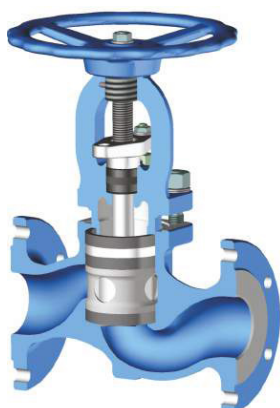
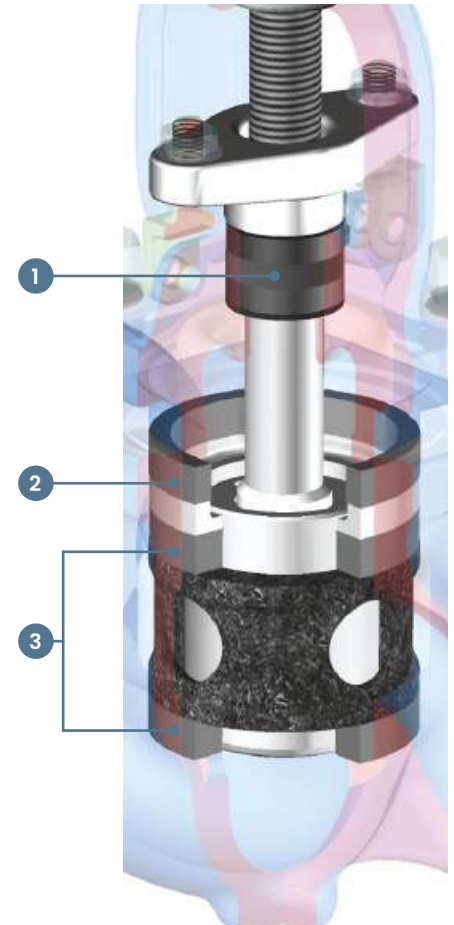

### Balanced Piston Valve – YVNB 65–200

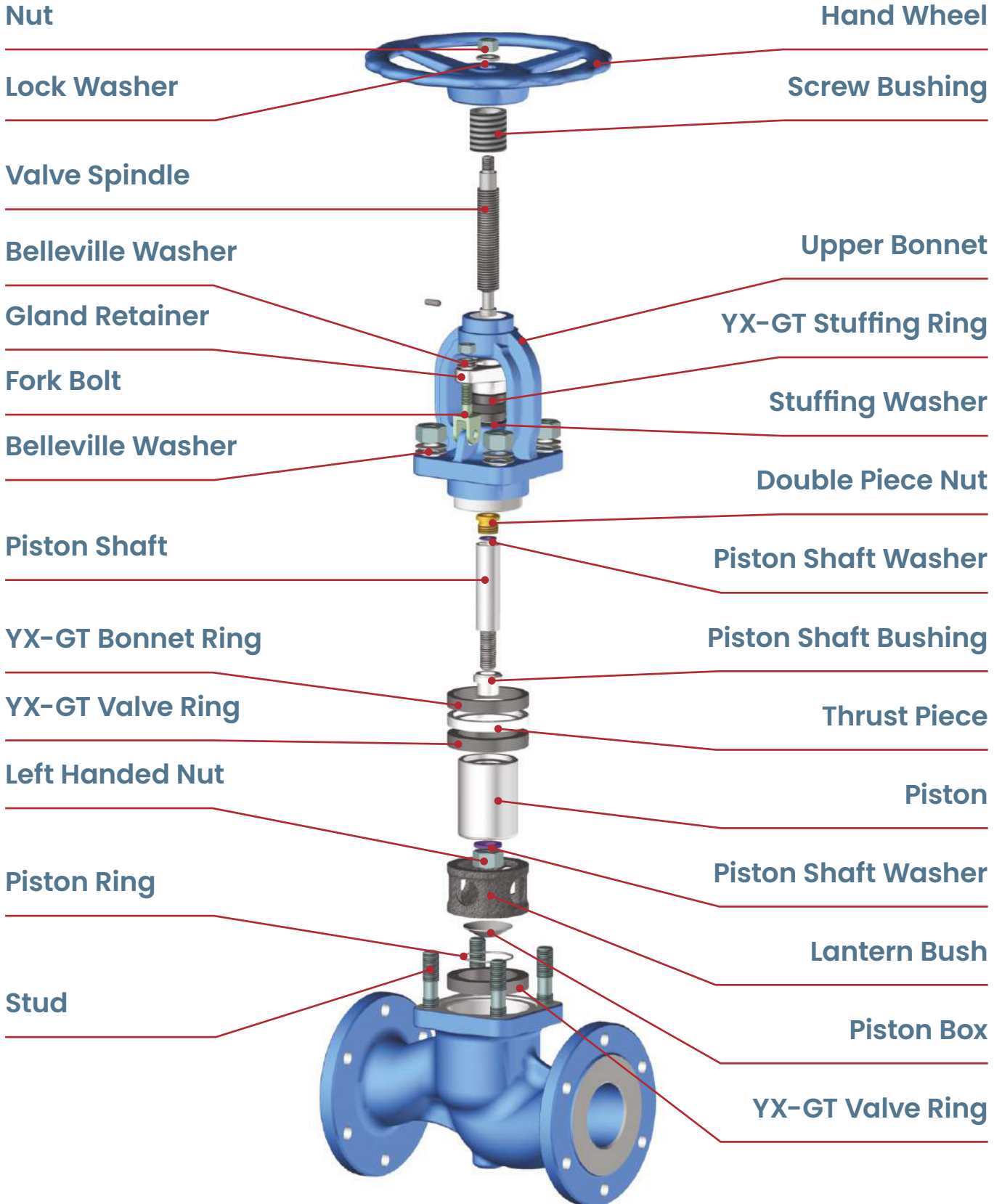

## Balanced Piston Valves – DN65–200 – YVNB–YPG Flanged

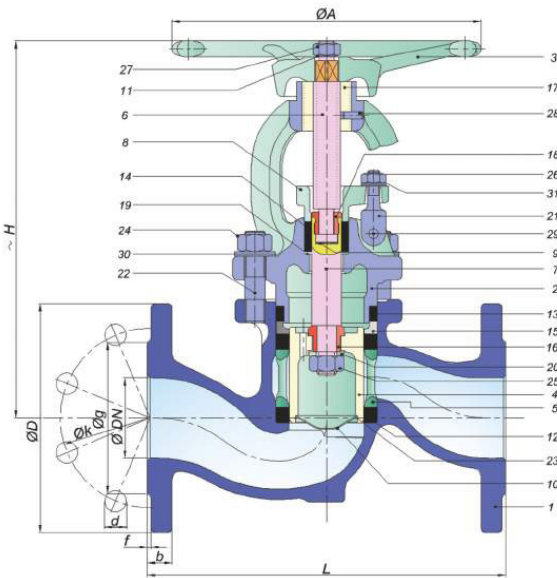

### Fluid Types

All kinds of fluids such as water, hot water, high temperature hot water, steam, thermal oil, LPG, fuel oil, pressurized air, etc.

Material Type	Cast Iron	Ductile Iron	Cast Steel	Stainless Steel
Size	DN65-200	DN65-200	DN65-200	DN65-200
Pressure Class	PN16	PN25	PN40	PN40
Dimensions	DIN EN 558/1.series	DIN EN 558/1.series	DIN EN 558/1.series	DIN EN 558/1.series
Assembly	Flanged according to DIN EN 1092-2	Flanged according to DIN EN 1092-2	Flanged according to DIN EN 1092-1	Flanged according to DIN EN 1092-1
Temperature	-10°C +300 °C	-10°C +350 °C	-10°C +400°C	-10°C +400°C
Material Code	2	8	7	9
Order Code	YPG.2F.___00	YPG.8F.___00	YPG.7F.___00	YPG.9F.___00

P.No	Part Name	Cast Iron	Ductile Iron	Cast Steel	St. Steel	St. Steel	P.No	Part Name	Cast Iron	Ductile Iron	Cast Steel	St. Steel	St. Steel
1	Body	GJL 250	0.7040	1.0619	1.4308	1.4408	17	Screw Bushing	Ms-58	Ms-58	Ms-58	Ms-58	Ms-58
2	Upper Bonnet	GJL 250	0.7040	1.0619	1.4308	1.4408	18	Double Piece Nut	Ms-58	Ms-58	Ms-58	1.4301	1.4301
3	Hand Wheel	GJL 200	GJL 200	GJL 200	GJL 200	GJL 200	19	Stuffing Washer	St-37+Gal.	St-37+Gal.	St-37+Gal.	1.4301	1.4401
4	Piston	1.4086	1.4086	1.4086	1.4308	1.4408	20	Piston Washer	Ms-58	Ms-58	Ms-58	1.4301	1.4401
5	Lantern Bush	GJL 200 + Phosphate	GJL 200 + Phosphate	GJL 200 + Phosphate	1.4308	1.4408	21	Fork Bolt	St-42	St-42	St-42	1.4301	1.4401
6	Valve Spindle	St-42	St-42	St-42	1.4301	1.4401	22	Stud	8.8+Gal.	8.8+Gal.	8.8+Gal.	A2-70	A2-70
7	Piston Shaft	1.4021	1.4021	1.4021	1.4301	1.4401	23	Piston Ring	1.4301	1.4301	1.4301	1.4301	1.4301
8	Gland Retainer	0.7040	0.7040	0.7040	1.4308	1.4408	24	Nut	8.8+Gal.	8.8+Gal.	8.8+Gal.	A2-70	A2-70
9	Piston Shaft Washer	1.4301	1.4301	1.4301	1.4301	1.4301	25	Left Handed Nut	A2-70	A2-70	A2-70	A2-70	A2-70
10	Piston Box	1.4301	1.4301	1.4301	1.4301	1.4401	26	Nut M10	8.8+Gal.	8.8+Gal.	8.8+Gal.	A2-70	A2-70
11	Lock Washer	55Si7	55Si7	55Si7	A2-70	A2-70	27	Nut	8.8+Gal.	8.8+Gal.	8.8+Gal.	A2-70	A2-70
12	Valve Ring	Graphite	Graphite	Graphite	Graphite	Graphite	28	Pin 6x15	St-42+Gal.	St-42+Gal.	St-42+Gal.	A2-70	A2-70
13	Bonnet Ring	Graphite	Graphite	Graphite	Graphite	Graphite	29	Sloted pin 8x22	8.8	8.8	8.8	1.4301	1.4301
14	Stuffing Ring	Graphite	Graphite	Graphite	Graphite	Graphite	30	Belleville Washer	50CrV4	50CrV4	50CrV4	A2-70	A2-70
15	Thrust Piece	GJL 200 + Phosphate	GJL 200 + Phosphate	GJL 200 + Phosphate	1.4308	1.4408	31	Belleville Washer (20/10.2x11)	50CrV4	50CrV4	50CrV4	A2-70	A2-70
16	Piston Shaft Bushing	1.4021	1.4021	1.4021	1.4301	1.4401							

DN			Dimensions			Assembly size																				
mm	inch	Type	L	H	A	PN16						PN25						PN40								
						D	b	g	Hole Nr.	d	k	f	D	b	g	Hole Nr.	d	k	f	D	b	g	Hole Nr.	d	k	f
65	2 1/2"	YVNB 65	290	306	250	185	20	122	4	19	145	3	185	20	118	8	19	145	3	185	22	122	8	18	145	2
80	3"	YVNB 80	310	327	250	200	22	138	8	19	160	3	200	22	132	8	19	160	3	200	24	138	8	18	160	2
100	4"	YVNB 100	350	374	280	220	24	158	8	19	180	3	235	24	156	8	23	190	3	235	24	162	8	22	190	2
125	5"	YVNB 125	400	447	320	250	26	188	8	19	210	3	270	26	184	8	28	220	3	270	26	188	8	26	220	2
150	6"	YVNB 150	480	477	360	285	26	212	8	23	240	3	300	26	211	8	28	250	3	300	28	218	8	26	250	2
200	8"	YVNB 200	600	561	400	340	30	268	12	23	295	3	360	30	274	12	28	310	3	375	34	285	12	30	320	2

\* For temperatures below -10°C, stud and nut material should be stainless steel.

## Temperature Pressure Diagrams

Pressure Class: PN16

Material: GJL 250

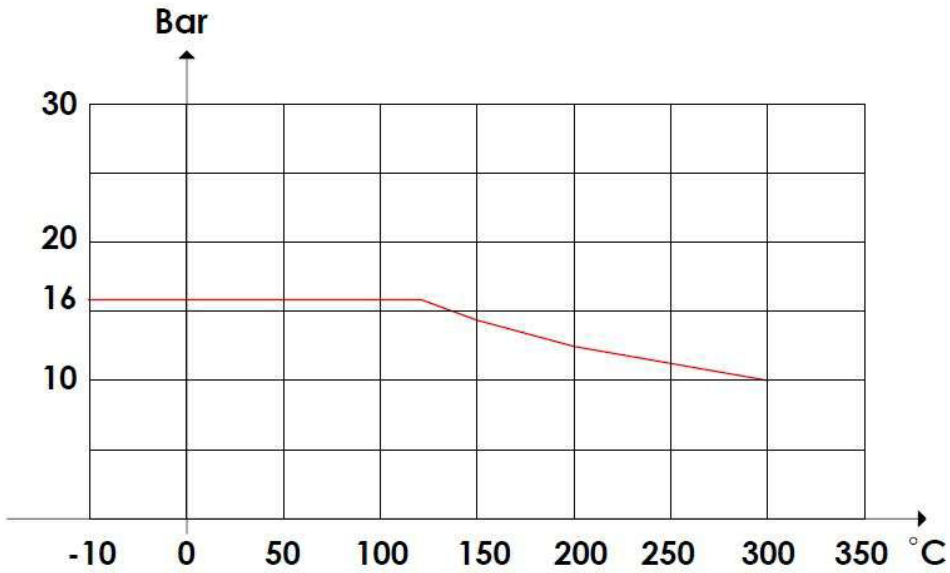

### Temperature Pressure Diagrams

Pressure Class: PN25  
Material: 0.7040



Pressure Class: PN40  
Material: 1.0619

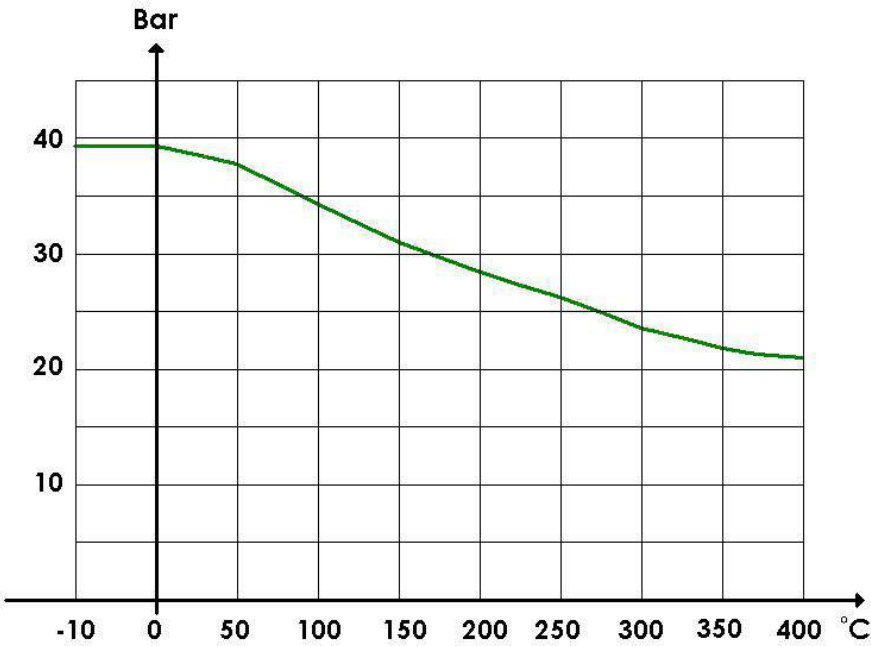

# Temperature Pressure Diagrams

## YVN 15-50

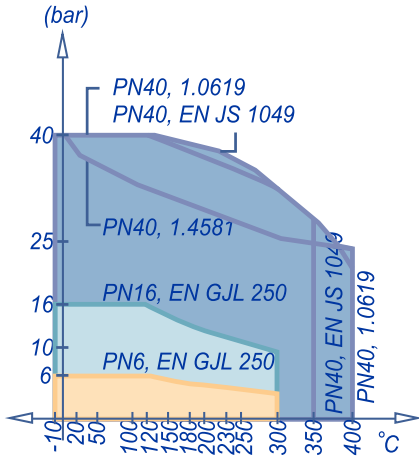

## YVNB 65-200

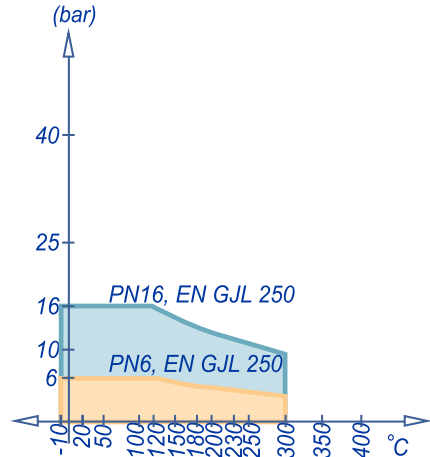

## YVMN 1/2" - 2"

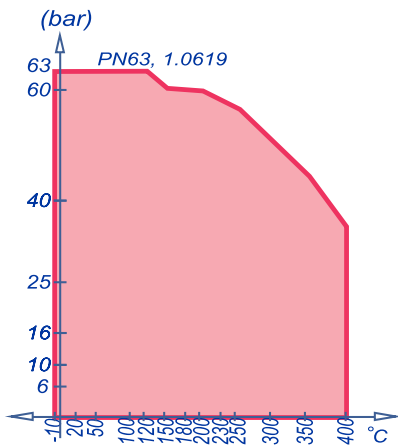

## YVSN

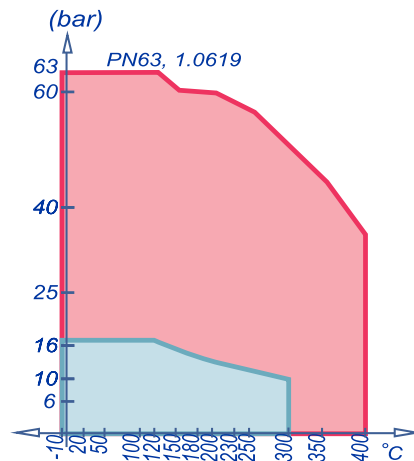

## Pressure drop calculation in piston valves

DN	ξ	Kv
15	4	4.5
20	4	8
25	4	12.5
30	4	20.5
40	4	32
50	4	50
65	6	69
80	6	104
100	6	163
125	7.2	233
150	7.2	335
200	7.5	582

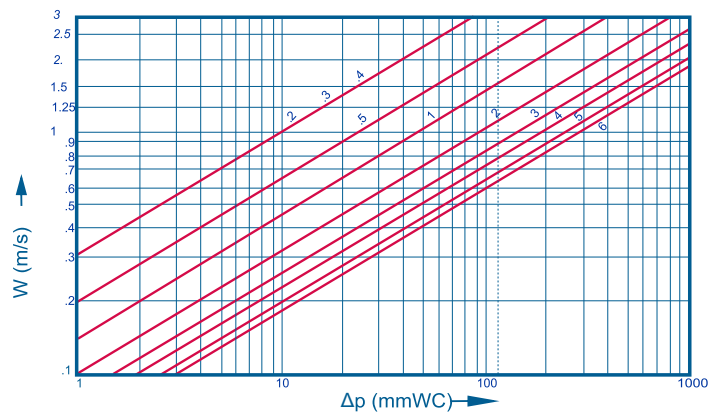

Pressure drop formula  $\Delta p =$  pressure drop (mmWC)

$$\Delta p = \xi \frac{W^2}{2g} \rho \text{ (mmWC)}$$

ξ : zeta value  
W : fluid velocity, m/s  
2g : 20 m/s<sup>2</sup>

$$\Delta p = \left( \frac{Q}{Kv} \right)^2 \times \frac{\rho}{1000}$$

ρ : 1000 kg/m<sup>3</sup>  
Kv : flow coefficient, m<sup>3</sup>/h. For  $\Delta p = 10$  mWC  
Q : flow rate, m<sup>3</sup>/h