

Carbon reinforced seats with superior temperature and wear resistance

MODU 83

3-pcs ball valve PN125/100

- Stainless steel "CF8M" and steel "WCB"
- 100% traceability - ProLog
- High quality industrial 3-pcs ball valve
- Closed pin bolts for easy cleaning
- Unique stuffing box ensuring long and reliable service
- Carbon reinforced seats with superior temperature and wear resistance
- Food grade materials used throughout the valve
- ISO 14001 certification



Make it better.

MODU[®]

MODU 83

3-pcs ball valve PN125/100 • EU1935/2004, FDA, ATEX, TA-LUFT, SIL3

Connections

Weld ends, ISO1127, SMS3008, EN12627 and BSPP threaded ends.

Usable for

Water, air, steam, oil etc.

Options (on request)

Body, end caps: Duplex, Hastelloy, titanium i.a.
 Seat rings: PTFE, Delrin, PEEK i.a.
 Connection: NPT, ISO11850, ASME Sch. etc.

Pressure rating

DN08F-DN40RB: 125bar / 2000psi
 DN40F-DN65RB: 100bar / 1500psi

Temperature

-40°C to 250°C

Accessories

- V-port ball (30°, 60°, 90°), for regulating purposes
- Precision coupling / bracket for regulating purposes
- Closed stem extension, TA-Luft approved stuffing box "TSM"
- Closed stem extension, without stuffing box
- Handle with position indication, lockable
- Position indication, handle operated (inductive or mechanical)

Spare parts

- Complete kit/set of gaskets
- Seat rings
- Joint (body) gaskets
- Ball

Developed for your industry



Additional specification can be requested.

Make it better.

MODU Valves A/S • moduvalves.com

Parts description, excerpt

Pos	Description	Material
1	Body.....	Stainless Steel CF8M or WCB
4	Seat.....	CTFE (25%C 75%PTFE)

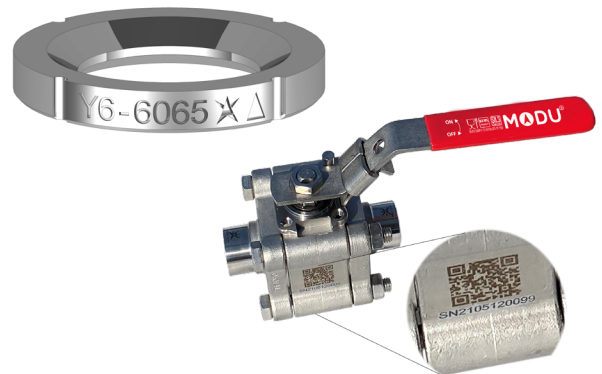
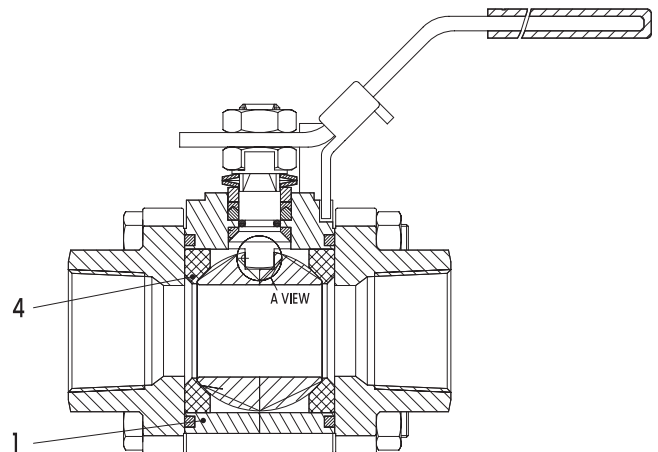

➤ Improve the quality

We help Engineers to improve the quality of your manufacturing process.

➤ Optimize total cost

We help Purchasing Officers to optimize total cost of production, prevent downtime and safeguard your brand.

➤ Work smarter

We help Maintenance Crews to work smarter, while preventing time-consuming mistakes.

MODU 83

3-pcs ball valve PN125/100 • EU1935/2004, FDA, ATEX, TA-LUFT, SIL3

Materials

Pos *	Description.....	Material
1	SE Body.....	Stainless Steel CF8M or WCB
2	SE Connection.....	Stainless Steel CF3M or WCB
3	SE Ball.....	Stainless Steel CF8M/AISI316
4	SEF Seat.....	CTFE (25%C 75%PTFE)
5	EF Joint gasket.....	PTFE / TFM1600
6	SEM Stem.....	Stainless Steel AISI316
7	EF Pyramid segment.....	CTFE (25%C 75%PTFE)
8	EF Stem seal V-ring....	MG1241 (5%C 20%R 75%PTFE)
9	Gland.....	Stainless Steel AISI304
10	Belleville washers..	Stainless Steel AISI301
11	Lock saddle.....	Stainless Steel AISI304
12	M Nut.....	Stainless Steel AISI304
13	Handle.....	Stainless Steel AISI304
14	Sleeve.....	Vinyl
15	Stop bolt.....	Stainless Steel AISI304
16	M Bolt.....	Stainless Steel AISI304
17	M Nut.....	Stainless Steel AISI304
18	Locking device.....	Stainless Steel AISI304
19	E Antistatic device....	Stainless Steel AISI316
20	EF O-ring.....	FPM
21	EF Grease.....	NLGI 2 food grade

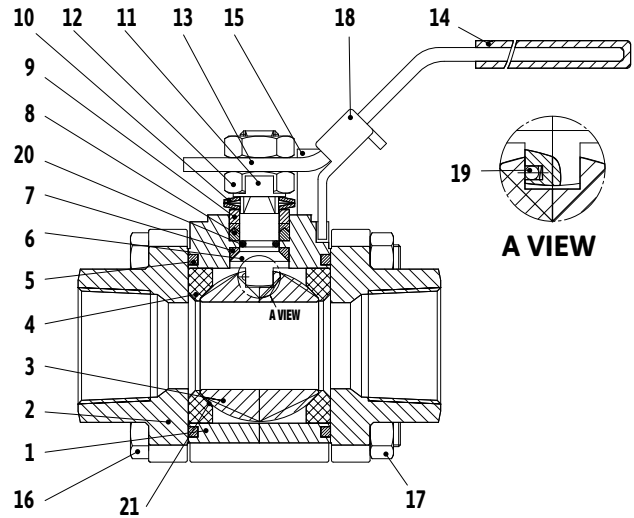

*Documentation 1-1 certificate on each valve

Each ball valve is serial numbered and covered by MODU's production log. This describes each individual body bolt as well as the tightening torque of the spindle nut. The torque of the ball valve is measured for final verification of the tolerance quality, which is all crucial for a uniform and correct actuator sizing. The production log can be viewed by scanning the valve's QR code and entering the serial number of the valve.

[S] 100% traceability - ProLog
The item is covered by heat number certificate and full traceability. The component will have a heat number embossed on the surface or be described under serial number in the production log. 3.1 material certificate for steel parts.

[E] The materials apply to declaration for food contact
EU-declaration no. 1935/2004
EU-declaration no. 10/2011
EU-declaration no. 2023/2006



[F] FDA 21 CFR

[M] Digital logging of tightening torques which are stored in the ball valve's production log as well as stem torque.

DIM		*) Torque [Nm]						Weight [kg]		Kv-value		Weld ends available as [R=Reduce bore] [F=Full bore]				
Weld	Thread	FB 10% Max bar	FB 50% Max bar	FB 100% Max bar	RB 10% Max bar	RB 50% Max bar	RB 100% Max bar	[kg]		[m3/t]		WCB EN 12627 ØG x T (ØD)	CF3M ISO 1127 ØG x T (ØD)	CF3M SMS3008** ØG x T (DN)		
								FB	RB	FB90°	RB90°					
DN08	1/4"	6,2	6,2	6,9	-	-	-	0,80	-	6,9	-	14 x 2 (10,0)	F	13,5 x 1,6 (10,3)	F	10,0 x 1,0 (8,0)
DN10	3/8"	6,2	6,2	6,9	6,2	6,2	6,9	0,80	0,66	6,9	6,9	17,5 x 3,35 (11,4)	F	17,2 x 1,6 (14,0)	F	12,0 x 1,0 (10,0)
DN15	1/2"	6,9	6,9	10	6,2	6,2	6,9	0,82	0,66	12,7	6,9	21,7 x 3,35 (15,0)	R/F	21,3 x 1,6 (18,1)	R/F	18,0 x 1,0 (10,0)
DN20	3/4"	9,2	9,2	13,8	6,9	6,9	10	1,28	0,87	29,2	12,7	27,2 x 3,35 (20,5)	R/F	26,9 x 1,6 (23,7)	R/F	25,0 x 1,2 (15,0)
DN25	1"	12,3	12,3	18,5	9,2	9,2	13,8	2,07	1,36	48,2	29,2	34 x 4,15 (25,7)	R/F	33,7 x 2,0 (29,7)	R/F	25,0 x 1,2 (20,0)
DN32	1 1/4"	20,0	20,0	33,8	12,3	12,3	18,5	2,65	2,01	73,1	48,2	42,7 x 4,15 (34,4)	R/F	42,4 x 2,0 (38,4)	R/F	32,0 x 1,2 (20,0)
DN40	1 1/2"	26,2	26,2	46,9	20,0	20,0	33,8	3,79	2,69	107,5	73,1	48,6 x 4,15 (40,3)	R/F	48,3 x 2,0 (44,3)	R/F	38,0 x 1,2 (32,0)
DN50	2"	26,9	32,3	59,2	26,2	26,2	46,9	5,51	4,04	215,0	107,5	60,5 x 4,6 (51,3)	R/F	60,3 x 2,6 (55,1)	R/F	51,0 x 1,2 (38,0)
DN65	2 1/2"	-	-	-	26,2	32,3	59,2	-	6,78	-	215,0	76,3 x 4,6 (67,1)	R/F	76,1 x 2,6 (70,9)	R/F	63,5 x 1,6 (50,0)

*) Torques are listed without safety factor at 20°C. See section for actuator dimensioning in the following pages.

**) For SMS butt weld ends please refer to the bore ØC when obtaining the Kv-value (i.e. Ø25x1,2mm (15) = DN15F/20R)

Make it better.

MODU Valves A/S • moduvalves.com

MODU 83

3-pcs ball valve PN125/100 • EU1935/2004, FDA, ATEX, TA-LUFT, SIL3

Dimensions

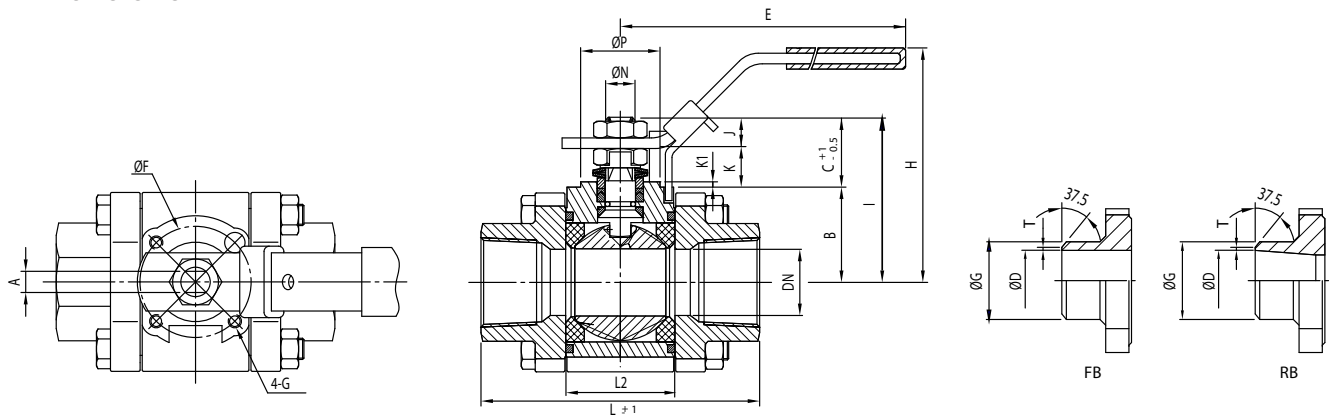

DIM	DN		A		B		C		E		ØF		G		H		I	
	F	R	F	R	F	R	F	R	F	R	F	R	F	R	F	R	F	R
1/4"	10	-	6.5	-	29.8	-	7.4	-	134	-	36	-	M5	-	64.3	-	37.2	-
3/8"	10	-	6.5	-	29.8	-	7.4	-	134	-	36	-	M5	-	64.3	-	37.2	-
1/2"	15	10	6.5	6.5	29	29.8	16.1	7.4	134	134	36	36	M5	M5	71.5	64.3	45.1	37.2
3/4"	20	15	6.5	6.5	33	29	18.1	16.1	134	134	36	36	M5	M5	76	71.5	51.1	45.1
1"	25	20	8	6.5	36	33	24.6	18.1	170	134	42	36	M5	M5	82.3	76	60.6	51.1
1-1/4"	32	25	8	8	40	36	24.3	24.6	170	170	42	42	M5	M5	87.3	82.3	64.3	60.6
1-1/2"	38	32	9.7	8	47.3	40	30.2	24.3	207	170	50	42	M6	M5	103.6	87.3	77.5	64.3
2"	50	38	9.7	9.7	69.5	47.3	26	30.2	207	207	50	50	M6	M6	121.6	103.6	95.5	77.5
2-1/2"	-	50	-	9.7	-	69.5	-	26	-	207	-	50	-	M6	-	121.6	-	95.5

DIM	J		K		K1		L		L2		ØP		ØN		ISO5211			
	F	R	F	R	F	R	F	R	F	R	F	R	F	R	F	R		
1/4"	6.1	-	1.3	-	0.5		64.8	-	20,5	-	25	-	9.5	-	F03	-		
3/8"	6.1	-	1.3	-	0.5		64.8	-	20,5	-	25	-	9.5	-	F03	-		
1/2"	7.3	6.1	8.8	1.3	2	0.5	72.5	64.8	24,5	20,5	25	25	9.5	9.5	F03	F03		
3/4"	8.8	7.3	9.3	8.8	2	2	85.4	72.5	31,4	24,5	25	25	9.5	9.5	F03	F03		
1"	11	8.8	13.6	9.3	2	2	105.3	85.4	41,3	31,4	30	25	11.1	9.5	F04	F03		
1-1/4"	9.7	11	14.6	13.6	2	2	111	105.3	48,4	41,3	30	30	11.1	11.1	F04	F04		
1-1/2"	12.2	9.7	18	14.6	2.2	2	127.3	111	56,3	48,4	35	30	14.3	11.1	F05	F04		
2"	12.6	12.2	13.4	18	1.5	2.2	142.8	127,3	71,4	56,3	35	35	14.3	14.3	F05	F05		
2-1/2"	-	12.6	-	13.4	-	1.5	-	145	-	71,4	-	35	-	14.3	-	F05		

Make it better.

MODU Valves A/S • moduvalves.com

MODU 83

3-pcs ball valve PN125/100 • EU1935/2004, FDA, ATEX, TA-LUFT, SIL3

Temperature vs. pressure table for CTFE seats

Valid for fluids and gasses. For steam and similar services contact MODU Valves A/S.

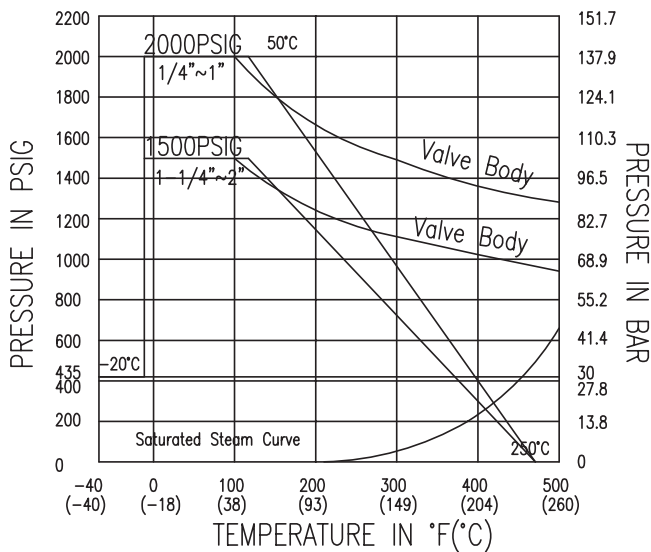

Actuator sizing

Media factor	Multiply by
Clean, particle free, lubricating (oil, hydraulic fluids etc)	1.00
Clean, particle free, non-lubricating (water, alcohol etc)	1.20
Moist gas or saturated steam	1.20
Dry gas or saturated steam	1.40
Gas, dirty unfiltered i.e. Natural gas	1.50
Particle filled, corrosive, solvents and polluted systems	2.00 #

Service factor	Multiply by
Simple on / off maneuvering	1.00
Regulating / Throttling	1.20
Maneuvering once per week	1.20
Maneuvering every second week or critical component	1.50

For actuator dimensioning:

Torque x Media factor x Service factor

Poluted systems will reduce the expected life span of the seat rings

Surface roughness

Part	Surface roughness μ (Ra)
Ball external	≤ 0.4
Ball internal	1.0~3.2
Stem	0.8
Body external	Cast
Body internal	1.0~3.2
Connection internal	1.0~3.2
Connection external	Cast

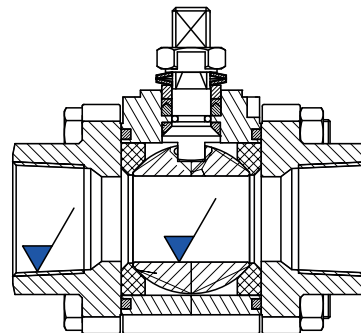

Make it better.

MODU Valves A/S • moduvalves.com