



**3-pcs.
FireSafe
ball valve**

MODU 88FS

3-pcs ball valve PN125/100/69

- Stainless steel "CF8M" and Steel "WCB"
- Firesafe according to API 607th
- 100% traceability - ProLog
- High quality industrial 3-pcs ball valve
- Closed pin blots for easy cleaning (up to 2-1/2")
- Unique stuffing box ensuring long and reliable service
- Carbon reinforced seats with superior temperature and wear resistance
- Direct mount of actuators
- ISO 14001 certification

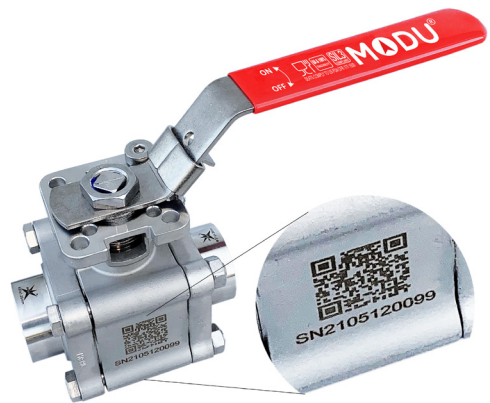

Make it better.

MODU[®]

MODU 88FS

3-pcs ball valve PN125/100/69 • ATEX, TA-LUFT, SIL3, API 607^{6th}

Connections

Weld ends, ISO1127, SMS3008, EN12627 and BSPP threaded ends.

Usable for

Water, air, steam, oil etc.

Options (on request)

Body, end caps: Duplex, Hastelloy, Titanium

Seat rings: PTFE, Delrin, PEEK i.a.

Connections: NPT, ASME, ISO11850

Pressure rating

DN08F-DN40RB: 125bar / 2000psi

DN40F-DN65RB: 100bar / 1500psi

DN50F-DN100F: 69bar / 1000psi

Temperature

-40°C to 250°C

Accessories

- V-port ball (30°, 60°, 90°), for regulating purposes
- Precision coupling / bracket regulating purposes
- Closed stem extension, TA-Luft approved stuffing box "TSM"
- Closed stem extension, without stuffing box
- Handle with position indication, lockable
- Position indication, handle operated (inductive or mechanic)

Parts description, excerpt

Pos	Description	Material
1	Body	Stainless Steel CF8M or WCB
4	Seat	CTFE (25%C 75%PTFE)
5	Joint gasket.....	Graphite
8	Stem seal	Graphite

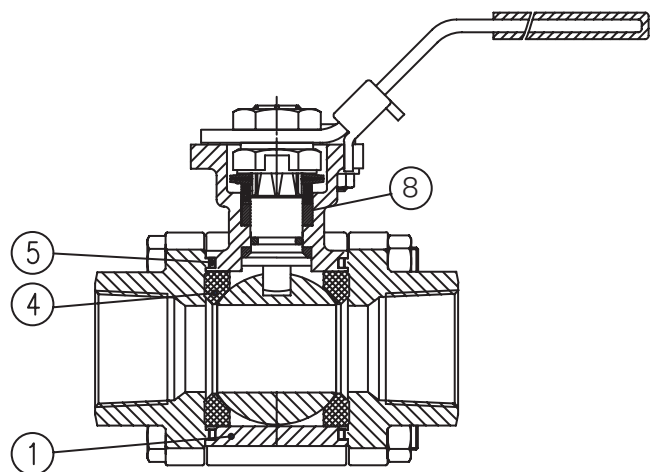

Developed for your industry



Additional specification can be requested.

Make it better.

MODU Valves A/S • moduvalves.com

➤ Improve the quality

We help Engineers to improve the quality of your manufacturing process.

➤ Optimize total cost

We help Purchasing Officers to optimize total cost of production, prevent downtime and safeguard your brand.

➤ Work smarter

We help Maintenance Crews to work smarter, while preventing time-consuming mistakes.

MODU 88FS

3-pcs ball valve PN125/100/69 • ATEX, TA-LUFT, SIL3, API 607^{6th}

Materials

Pos *	Description.....	Material
1	Body.....	Stainless Steel CF8M or WCB
2	End Cap.....	Stainless Steel CF8M or WCB
3	Ball.....	Stainless Steel CF8M / AISI316
4	Seat.....	RTFE (25%C 75%PTFE)
5	Joint Gasket.....	Graphite
6	Stem seal.....	RTFE (25%C 75%PTFE)
7	Stem.....	Stainless Steel AISI316
8	Stem packing.....	Graphite
8.1	Stem packing.....	RTFE (25% Glas 75%PTFE)
9	Gland.....	Stainless Steel AISI304
10	Lock saddle.....	Stainless Steel AISI304
11	Stem Nut.....	Stainless Steel AISI304
12	Handle.....	Stainless Steel AISI304
13	Handle Sleeve.....	Vinyl
14	Stem Washer.....	Stainless Steel AISI304
15	Bolt.....	Stainless Steel AISI304
16	Bolt Nut.....	Stainless Steel AISI304
17	Belleville Washer....	Stainless Steel AISI301
18	Stop Pin.....	Stainless Steel AISI304
19	Pin Nut.....	Stainless Steel AISI304
20	Locking device.....	Stainless Steel AISI304
21	Antistatic device....	Stainless Steel AISI316
22	O-Ring.....	FPM
23	Spring.....	Stainless Steel AISI316
24	Washer.....	Stainless Steel AISI304

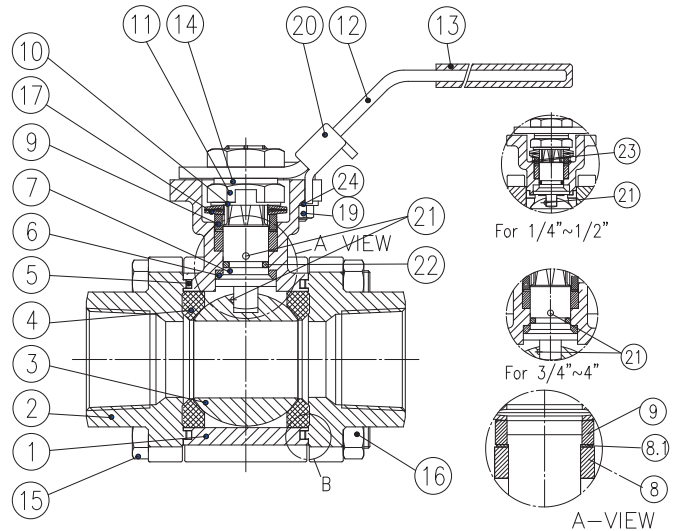

*Documentation 1-1 certificate on each valve

Each ball valve is serial numbered and covered by MODU's production log. This describes each individual body bolt as well as the tightening torque of the spindle nut. The torque of the ball valve is measured for final verification of the tolerance quality, which is all crucial for a uniform and correct actuator sizing. The production log can be viewed by scanning the valve's QR code and entering the serial number of the valve.

[s] 100% traceability - ProLog

The item is covered by heat number certificate and full traceability. The component will have a heat number embossed on the surface or be described under serial number in the production log. 3.1 material certificate for steel parts.

DIM	Weld Thread	*) Torque [Nm]						Weight [kg]		Kv-value [m ³ /t]		Weld ends available as [R=Reduce bore] [F=Full bore]				
		FB 10% Max bar	FB 50% Max bar	FB 100% Max bar	RB 10% Max bar	RB 50% Max bar	RB 100% Max bar	FB	RB	FB 90°	RB 90°	WCB EN 12627 ØG x T (ØD)	CF3M ISO 1127 ØG x T (ØD)	CF3M SMS3008** ØG x T (ØC)		
DN08	1/4"	6,9	6,9	7,7	-	-	-	0.89	-	6.9	-	14.0 x 2 (10.0)	F	13.5 x 1.6 (10.3)	F	10.0 x 1.0 (11.5)
DN10	3/8"	6,9	6,9	7,7	-	-	-	0.88	-	6.9	-	17.5 x 3,35 (11.4)	F	17.2 x 1.6 (14.0)	F	12.0 x 1.0 (11.5)
DN15	1/2"	6,9	6,9	10,0	6,9	6,9	7,7	0.82	0.84	12.7	6.9	21.7 x 3.35 (15.0)	R/F	21.3 x 1.6 (18.1)	R/F	18.0 x 1.0 (12.6)
DN20	3/4"	9,2	9,2	15,4	6,9	6,9	10,0	1.29	0.85	29.2	12.7	27.2 x 3.35 (20.5)	R/F	26.9 x 1.6 (23.7)	R/F	25.0 x 1,2 (15.0)
DN25	1"	13,1	13,1	20,0	9,2	9,2	15,4	2.01	1.41	48.2	29.2	34 x 4.15 (25.7)	R/F	33.7 x 2.0 (29.7)	R/F	25.0 x 1.2 (20.0)
DN32	1 1/4"	20,0	20,0	33,8	13,1	13,1	20,0	2.76	2.17	73.1	48.2	42.7 x 4.15(34.4)	R/F	42.4 x 2,0 (38.4)	R/F	32.0 x 1.2 (20,0)
DN40	1 1/2"	26,9	26,9	51,5	20,0	20,0	33,8	4.21	2.87	107.5	73.1	48.6 x 4.15(40.3)	R/F	48.3 x 2.0 (44.3)	R/F	38.0 x 1.2 (32.0)
DN50	2"	27,7	33,1	60,8	26,9	26,9	51,5	5.83	4.49	215.0	107.5	60.5 x 4.6 (51.3)	R/F	60.3 x 2.6 (55.1)	R/F	51.0 x 1.2 (38.0)
DN65	2 1/2"	52,3	83,8	141,5	27,7	33,1	60,8	11.00	6.94	275.2	215.0	76.3 x 4.6 (67.1)	R/F	76.1 x 2.6 (70.9)	R/F	63.5 x 1.6 (50.0)
DN80	3"	67,7	108,5	183,1	52,3	83,8	141,5	14.78	12.64	498.8	275.2	88.9 x 4.45 (80.0)	R/F	88.9 x 2.6 (83.7)	R/F	76.1 x 1.6 (65.0)
DN100	4"	87,7	167,0	254,6	67,7	108,5	183,1	23.30	16.00	877.2	498.8	116 x 6.45 (103.1)	R/F	114.3 x 2.6 (109.1)	R/F	101.6 x 2.0 (76.0)

*) Torques are listed without safety factor at 20°C. See section for actuator sizing in the following pages.

**) For SMS butt weld ends please refer to the bore (ØC) when reading the Kv-value. Ex. (Ø25x1,2 (15) = DN15F/20R)

Make it better.

MODU Valves A/S • moduvalves.com

MODU 88FS

3-pcs ball valve PN125/100/69 • ATEX, TA-LUFT, SIL3, API 607^{6th}

Dimensions

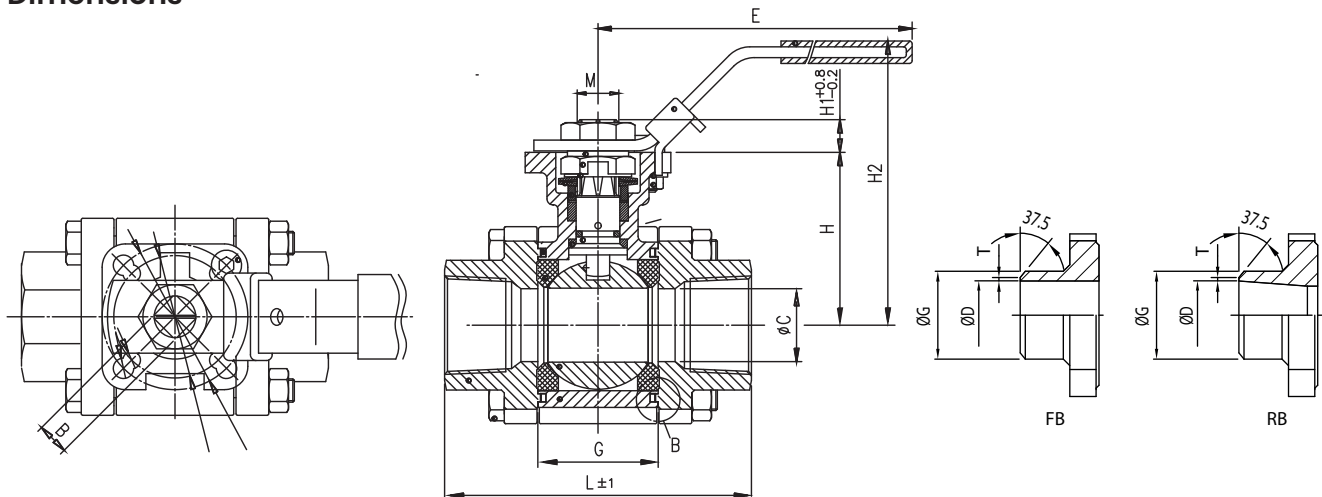

DIM	ØC [mm]		B [mm]		L [mm] BSPP		L [mm] ISO		L [mm] SMS		L2 [mm]		E [mm]		H [mm]	
	F	R	F	R	F	R	F	R	F	R	F	R	F	R	F	R
1/4"	11.5	-	9	-	75.0	-	75.0	-	-	-	24.5	-	139	-	42.6	-
3/8"	12.6	-	9	-	75.0	-	75.0	-	68.8	-	24.5	-	139	-	42.6	-
1/2"	15	12.6	9	9	72.5	75.0	75.0	75.0	75.0	75.0	24.5	24.5	139	139	42.6	42.6
3/4"	20	15	9	9	85.4	72.5	90.0	74.8	90.0	74.8	31.4	24.5	139	139	46.9	42.6
1"	25	20	11	9	105.3	85.4	110.0	89.8	110.0	89.8	41.3	31.4	165	139	59.3	46.9
1-1/4"	32	25	11	11	111.0	105.3	115.0	109.4	-	109.4	48.4	41.3	165	165	62.6	59.3
1-1/2"	38	32	14	11	127.3	111.0	130.0	114.4	-	114.4	56.3	48.4	215	165	79.0	62.6
2"	50	38	14	14	142.8	127.3	142.8	130.0	-	130.0	71.4	56.3	215	215	87.7	79.0
2-1/2"	65	50	17	14	185.0	145.0	185.0	145.0	-	145.0	86.6	71.4	300	215	108.7	87.7
3"	76	65	17	17	205.0	185.0	205.0	185.0	-	185.0	99.0	86.6	370	300	117.7	108.7
4"	100	80	17	17	240.0	205.0	240.0	205.0	-	205.0	127.0	99.0	370	370	133.7	117.7

DIM	H1 [mm]		H2 [mm]		M		ISO5211	
	F	R	F	R	F	R	F	R
1/4"	7.6	-	77.0	-	7/16"UNF	-	F03/F04	-
3/8"	7.6	-	77.0	-	7/16"UNF	-	F03/F04	-
1/2"	7.6	7.6	77.0	77.0	7/16"UNF	7/16"UNF	F03/F04	F03/F04
3/4"	8.6	7.6	82.0	77.0	7/16"UNF	7/16"UNF	F03/F04	F03/F04
1"	10.4	8.6	98.5	82.0	9/16"UNF	7/16"UNF	F04/F05	F03/F04
1-1/4"	10.4	10.4	102.0	98.5	9/16"UNF	9/16"UNF	F04/F05	F04/F05
1-1/2"	13.4	10.4	128.0	102.0	3/4"UNF	9/16"UNF	F05/F07	F04/F05
2"	13.4	13.4	137.0	128.0	3/4"UNF	3/4"UNF	F05/F07	F05/F07
2-1/2"	16.8	13.4	167.0	137.0	M24	3/4"UNF	F07/F10	F05/F07
3"	17.8	16.8	176.0	167.0	M24	M24	F07/F10	F07/F10
4"	16.8	17.8	192.0	176.0	M24	M24	F07/F10	F07/F10

Make it better.

MODU Valves A/S • moduvalves.com

MODU 88FS

3-pcs ball valve PN125/100/69 • ATEX, TA-LUFT, SIL3, API 607^{6th}

Temperature vs. pressure table for CTFE seats

Valid for fluids and dry gasses. For steam and similar services, contact MODU Valves A/S.

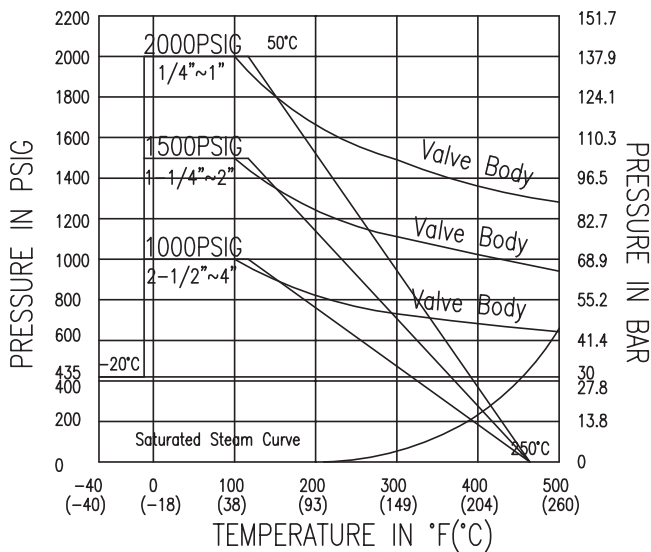

Actuator sizing

Media factor	Multiply by
Clean, particle free, lubricating (oil, hydraulic fluids etc)	1.00
Clean, particle free, non-lubricating (water, alcohol etc)	1.20
Moist gas or saturated steam	1.20
Dry gas or superheated steam	1.40
Gas, dirty unfiltered i.e. Natural gas	1.50
Particle filled, corrosive, solvents and polluted systems	2.00 #

Service factor	Multiply by
Simple on / off maneuvering	1.00
Regulating / Throttling	1.20
Maneuvering once per week	1.20
Maneuvering every second week or critical component	1.50

For actuator dimensioning:

Torque x Media factor x Service factor

Poluted systems will reduce the expected life span of the seat rings